



AST Schweiz

# AST Schweiz Schmiertechnik

## Minimalmengenschmierung

(LubeTool / MMS / MQL / MMKS)



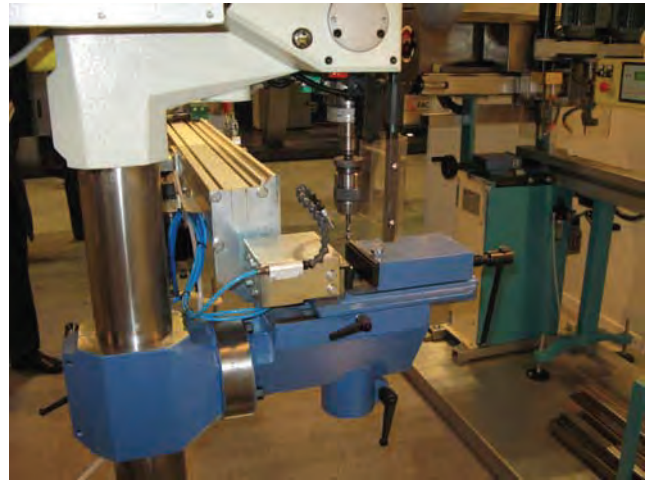



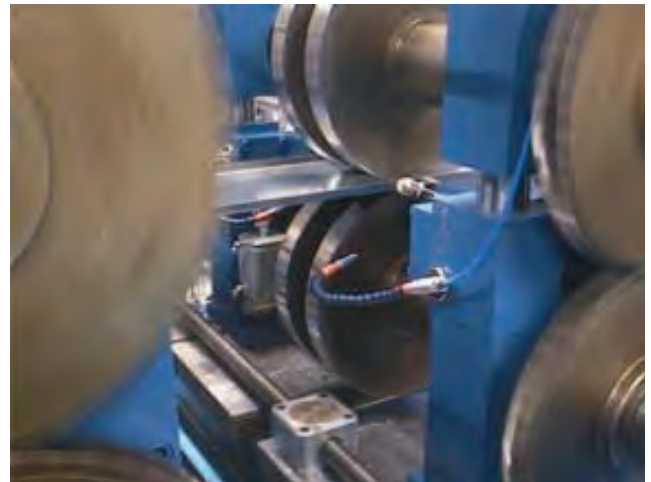
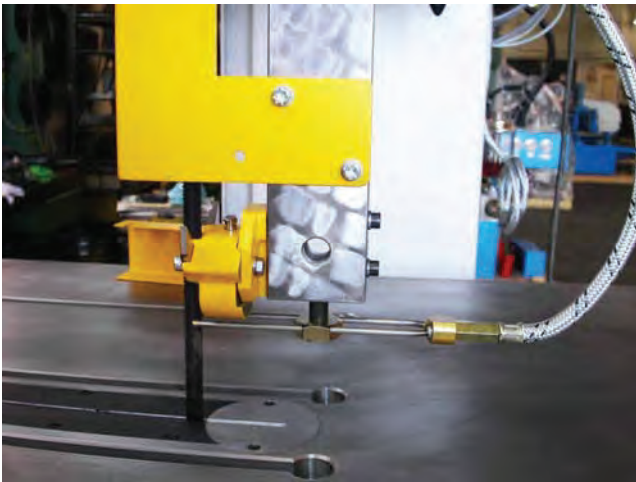

<b>INDICE</b>	<b>INDEX</b>	<b>PAGINA PAGE</b>
INTRODUZIONE	<i>INTRODUCTION</i>	5
APPLICAZIONI	<i>MAIN ADVANTAGES</i>	6-9
PRINCIPALI VANTAGGI	<i>APPLICATIONS</i>	10
PRINCIPIO DI FUNZIONAMENTO	<i>WORKING PRINCIPLE</i>	11-13
UNITA' UCFG, UCGF-SE, AGGF, AGGF-SE, UCSG, UCSG-SE, AGSG E AGSG-SE	<i>UNITS UCFG, UCGF-SE, AGGF, AGGF-SE, UCSG, UCSG-SE, AGSG E AGSG-SE</i>	14-28
UNITA' MC-EL-3P-4P-5P-6P-7P, MC-EL-3M-4M-5M-6M-7M, MC-EL-2P, MC-EL-2M, MINI-GF-EL, MINI-GF, MINI-SG-EL, MINI-SG, MINI-035-WFG E MINI-035-FG	<i>UNITS MC-EL-3P-4P-5P-6P-7P, MC-EL-3M-4M-5M-6M-7M, MC-EL-2P, MC-EL-2M, MINI-GF-EL, MINI-GF, MINI-SG-EL, MINI-SG, MINI-035-WFG E MINI-035-FG</i>	29-54
UNITA' MIX	<i>UNIT MIX</i>	55-59
TUBI COASSIALI	<i>COAXIAL FEELING LINES</i>	60
TERMINALI CON UGELLO	<i>END TUBES WITH NOZZLE</i>	61-67
UGELLI A SELLA PER SEGATRICI A NASTRO	<i>SADDLE NOZZLE FOR BAND SAW MACHINES</i>	68-71
UGELLI A SELLA PER SEGATRICI CIRCOLARI	<i>SADDLE NOZZLE FOR CIRCULAR SAW MACHINES</i>	71-73
UGELLO PER SEGATRICI VERTICALI	<i>NOZZLE FOR VERTICAL BLADE</i>	74
PASSAPARETE PER TUBO COASSIALE	<i>BULKHEAD CONNECTION FOR COAXIAL HOSE</i>	75
APPLICAZIONI	<i>APPLICATIONS</i>	76-92
OLIO VEGETALE	<i>VEGETABLE OIL</i>	93
COMPONENTI	<i>COMPONENTS</i>	94-110



## INTRODUZIONE

I SISTEMI DI LUBRIFICAZIONE MINIMALE LUBETOOL SONO STATI PROGETTATI PER SOSTITUIRE LA TRADIZIONALE LUBRIFICAZIONE AD EMULSIONE D'OLIO O OLIO INTERO NELLE LAVORAZIONI CON ASPORTAZIONE DI TRUCIOLO, STAMPAGGIO E DEFORMAZIONE A FREDDO.

UTILIZZANO LUBRIFICANTI VEGETALI (A BASE NATURALE) CHE SOSTITUISCONO I TRADIZIONALI FLUIDI ELIMINANDO L'OBBLIGO DI REGISTRAZIONE E SMALTIMENTO DEI LIQUIDI ESAUSTI.

LE MICRO POMPE PNEUMATICHE DOSANO DELLE MINIME QUANTITA' DI LUBRIFICANTE CHE SONO TRASPORTATE DA UN FLUSSO DI ARIA COMPRESSA VERSO IL PUNTO DI CONTATTO UTENSILE/PEZZO SENZA CREARE NEBBIA O INQUINAMENTO. IL LUBRIFICANTE E' CONSUMATO DURANTE LA FASE DI LAVORAZIONE.

SI OTTIENE UN IMMEDIATO INCREMENTO DELLA PRODUTTIVITA' IN QUANTO VENGONO ELIMINATI I TEMPI DERIVATI DALLA PULIZIA DELLA MACCHINA, DELLA ZONA DI LAVORO E DEI PEZZI.

UN ULTERIORE VANTAGGIO NELLA RIDUZIONE DEI COSTI E' DERIVATO DALL'INCREMENTO DELLA DURATA DELL'UTENSILE CHE ,MANTENUTO AD UNA TEMPERATURA AMBIENTE AUMENTA DRASTICAMENTE LA SUA VITA.

SI ELIMINANO INOLTRE I PROBLEMI DI SALUTE DERIVATI DAL CONTATTO CON I FLUIDI TRADIZIONALI.

## INTRODUCTION

*THE ILC MICRO-LUBRICATION SYSTEMS ARE DESIGNED FOR USE PRIMARILY IN THE VARIED METAL CUTTING AND FORMING PROCESSES TO ENABLE THE REPLACEMENT OF FLOOD AND WATER-SOLUBLE COOLANTS.*

*DUE TO THE WAY THE SYSTEMS DELIVER A PRECISE MINIMAL QUANTITY OF HEAVIER THAN AIR LUBRICATING OIL DROPLETS TO THE CUTTING EDGE VIA INDIVIDUALLY ADJUSTABLE PNEUMATIC PUMPS THERE IS NO MISTING EFFECT IN THE ATMOSPHERE. NO GENERATION OF FRICTION / HEAT BETWEEN THE WORK SURFACE AND THE TOOL CUTTING EDGE, AND THE LUBRICATING OIL IS CONSUMED IN THE MACHINING PROCESS.*

*JUST A SMALL QUANTITY OF OIL DOES THE JOB AND HE IS NATURALLY CONSUMED IN THE CUTTING PROCESS, SO THERE IS NO HARMFUL MISTING OR HAZARDOUS WASTE DISPOSAL TO WORRY ABOUT AND THAT CAN MEAN HIGHER PRODUCTIVITY, SINCE YOU DO NOT SPEND TIME CLEANING PARTS OR DISPOSING OF USED COOLANTS.*

*THEY PREVENT HEAT BUILD-UP AND CONTROL HEAT DISTORTION, SO YOU GET A TRUER CUT AND CLEANER MACHINE OPERATION. SINCE TOOLS AND PARTS STAY AT ROOM TEMPERATURE DURING CUTTING OPERATION, TOOL LIFE IS DRAMATICALLY INCREASED AND MAINTENANCE AND REPLACEMENT COSTS ARE REDUCED. REDUCED HANDLING AND STORAGE OF HAZARDOUS MATERIALS MEANS A SAFER, CLEANER WORKING ENVIRONMENT. AND CLEAN-UP IS EASY, USING JUST SOAP AND HOT WATER (160 °F / 70 °C).*

## VANTAGGI

**AMBIENTE DI LAVORO PULITO**  
**MAGGIORE PRODUTTIVITA'**  
**INCREMENTO DELLA DURATA DELL'UTENSILE**  
**MIGLIORE FINITURA DELLE SUPERFICI**  
**RIDUZIONE DEI COSTI**  
**MIGLIORAMENTO DELLE TOLLERANZE DI LAVORAZIONE**  
**RIDUZIONE DEL CONSUMO DI LUBRIFICANTE DEL 90%**  
**ELIMINAZIONE DELLE OPERAZIONI DI SMALTIMENTO DEI LIQUIDI ESAUSTI**  
**TRUCIOLI ASCIUTTI**  
**RIDUZIONE DEI TEMPI DI FERMO MACCHINA**  
**INCREMENTO DELLA PRODUTTIVITA'**  
**IMMEDIATO AMMORTAMENTO DELL'ACQUISTO**

## ADVANTAGES

**A CLEANER SAFER WORKING ENVIRONMENT**  
**HIGHER PRODUCTIVITY**  
**INCREASED TOOL LIFE**  
**BETTER SURFACE FINISH**  
**COST REDUCTION**  
**THE ABILITY TO MACHINE TO HIGHER TOLERANCES**  
**LUBROREFRIGERANT CONSUMPTION REDUCTION 90% LOWER**  
**NO COOLANT HANDLING OR DISPOSAL PROBLEMS**

**DRY CHIPS (SWARF)**  
**LESS MACHINE DOWN TIME**  
**INCREASED PRODUCTIVITY**  
**SHORT PAY BACK TIME**



## APPLICAZIONI

## APPLICATIONS

RISULTATI OTTIMI SONO STATI RAGGIUNTI NELLE SEGUENTI APPLICAZIONI

PROVEN RESULTS IN THE FOLLOWING PRIMARY APPLICATIONS

SEGATRICI A NASTRO



BAND SAWING

SEGATRICI A DISCO



CIRCULAR SAWING

FRESATURA



MILLING

INCISIONE



ENGRAVING

FILETTATURA – MASCHIATURA



TAPPING

ALESATURA



BORING





FORATURA



*DRILLING*

BROCCIATURA



*BROACHING*

AFFILATURA UTENSILI

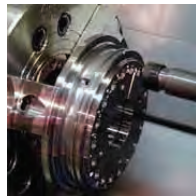

*TOOL AND CUTTER GRINDING*

RULLATURA



*ROLLING*

DENTATURA



*GEAR CUTTING*

PIEGATURA

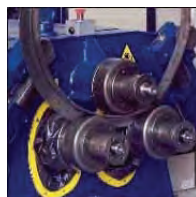

*BENDING*

PUNZONATURA



*PUNCHING*



CALIBRATURA – PROFILATURA



*ROLLFORMING*

CURVATURA TUBI



*PIPES BENDING*

STAMPAGGIO A FREDDO



*STAMPING*

TORNITURA A LASTRA



*METAL SPINNING*

NASTRI E COILS



*BELTS AND COILS*

CONVOGLIATORI AEREI



*MONO AND BI-RAILS CONVEYORS*

CATENE



*CHAINS*







## PRINCIPALI VANTAGGI DEL SISTEMA LUBETOOL

IL SISTEMA LUBETOOLS REGOLA ED EROGA DELLE ESATTE QUANTITA' DI LUBRIFICANTE DA 0 MM<sup>3</sup> A 41 MM<sup>3</sup>.

DOSAGGIO ED EROGAZIONE EFFETTUATI MEDIANTE UNA MICRO – POMPA A COMANDO PNEUMATICO A SEMPLICE EFFETTO.

IL LUBRIFICANTE E' SPRUZZATO CON ESTREMA PRECISIONE TRAMITE UN FLUSSO D'ARIA ED UN UGELLO DI PROIEZIONE VERSO IL PUNTO DI CONTATTO. SONO ELIMINATE ATOMIZZAZIONI E NEBBIE D'OLIO.

LA PORTATA DEL LUBRIFICANTE PUÒ ESSERE REGOLATA INDIPENDENTEMENTE FRA I VARI PUNTI DI UTILIZZO.

POSSONO ESSERE INSERITE DELLE MICROPOMPE AGGIUNTIVE IN QUALUNQUE MOMENTO. E' SUFFICIENTE ORDINARE IL KIT DI ASSIEME.

L'INSTALLAZIONE IN MACCHINARI PRE-ESISTENTI RICHIEDE DELLE MINIME MODIFICHE DEI SISTEMI DI COMANDO. IN MOLTI CASI NON E' RICHiesta ALCUNA MODIFICA.

UN GENERATORE DI FREQUENZA PNEUMATICO PERMETTE L'IMPOSTAZIONE DEI CICLI DI FREQUENZA.

ESTREMA FACILITA' DI REGOLAZIONE DELL'ARIA E DELLA QUANTITA' DI OLIO.

SERBATOI CON CAPIENZA PREVISTA PER LUNGA DURATA.

TUBAZIONI COASSIALI DI MANDATA FORNITE PRE – CABLATE ALL'UNITA' CON LUNGHEZZA STANDARD 5M. LUNGHEZZE DIFFERENTI POSSONO ESSERE FORNITE SU RICHIESTA.

DISPONIBILITA' DI DIFFERENTI UGELLI.

## THE UNIQUE ADVANTAGES OF LUBETOOL

LUBETOOLS REGULATE THE LUBRICANT SUPPLIED IN EXACT QUANTITIES ADJUSTABLE FROM 0 MM<sup>3</sup> TO 41 MM<sup>3</sup> – NO GUESSWORK.

100% PNEUMATICALLY CONTROLLED POSITIVE DISPLACEMENT PUMPS.

LUBRICANT IS CARRIED BY AIR, WITH PINPOINT ACCURACY. HAZARDOUS ATOMIZING AND "MIST" ARE ELIMINATED.

ALL PUMPS AND NOZZLE OPERATE INDEPENDENTLY FOR LUBRICANT.

ADDITIONAL PUMPS CAN BE ADDED IN THE FIELD. JUST ORDER A COMPLETE PUMP ASSEMBLY.

MINIMAL OR NO EQUIPMENT MODIFICATION IS REQUIRED FOR SYSTEM INSTALLATION.

A PNEUMATIC TIMING DEVICE (FREQUENCY GENERATOR) WITH A CONTROL RANGE.

EASY LUBRICANT AND AIR FLOW ADJUSTMENT.

DURABLE RESERVOIR.

STANDARD HOSE LENGTH IS 5 M. ADDITIONAL HOSE LENGTH AVAILABLE UPON REQUEST.

MULTIPLE NOZZLE TYPES AVAILABLE.

## I SISTEMI LUBETOOL LAVORANO PER VOI!

INCREMENTO DELLA PRODUZIONE.

INCREMENTO DELLA VITA DELL'UTENSILE.

ELIMINAZIONE DI FUMI E PARTICELLE D'OLIO – PEZZI PULITI - TRUCIOLI ASCIUTTI.

## LUBETOOL WILL GET THE JOB DONE FOR YOU!

PRODUCTION RATES WILL INCREASE.

TOOL LIFE WILL IMPROVE.

HAZARDOUS AIRBORNE PARTICLES, WASTE DISPOSAL HASSLES AND PARTS CLEANING WILL BE ELIMINATED.



## PRINCIPIO DI FUNZIONAMENTO GOCCE NON LITRI!

LA MICRO POMPA PNEUMATICA DOSA UNA PICCOLISSIMA QUANTITA' DI LUBRIFICANTE CHE, ATTRAVERSO IL TUBO CAPILLARE INTERNO DELLA TUBAZIONE COASSIALE, ARRIVA ALL'UGELLO DI SPRUZZO. IL LUBRIFICANTE VIENE PRELEVATO DALL'ARIA COMPRESA CHE LO POLVERIZZA E LO PROIETTA VERSO IL PUNTO DI CONTATTO UTENSILE/PEZZO, FORMANDO UN RIVESTIMENTO SOTTILE SULL'UTENSILE CHE RIDUCE L'ATTRITO GENERATO DALLA LAVORAZIONE.

POMPA PNEUMATICA DOSATRICE

## WORKING PRINCIPLE DROPS INSTEAD OF LITERS!

AN ADJUSTABLE POSITIVE DISPLACEMENT METERING PNEUMATIC PUMP DELIVERS A MINIMAL QUANTITY OF LUBRICANT ALONG A CAPILLARY TUBE FITTED INSIDE LENGTH OF THE AIR LINE TO THE NOZZLE HEAD. AT THIS POINT THE LUBRICANT DROPLET IS INTRODUCED INTO THE AIR STREAM AND TRANSPORTED TO THE CUTTING EDGE. THE LUBRICANT FORMS A THIN EVEN COAT ON THE CUTTING EDGE GREATLY REDUCING THE FRICTIONAL HEAT.

POSITIVE DISPLACEMENT METERING PNEUMATIC PUMP

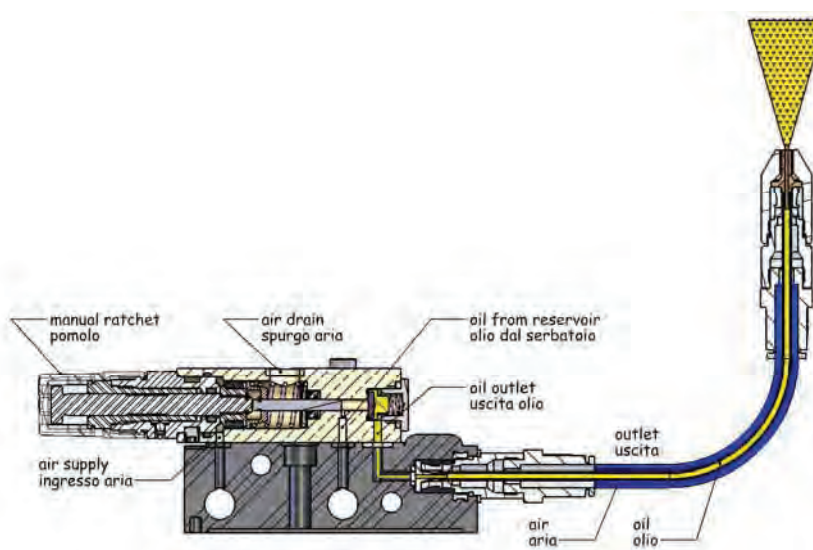

FUNZIONAMENTO

OPERATION

LA POMPA PNEUMATICA A SEMPLICE EFFETTO E' AZIONATA CON UNA PRESSIONE DELL'ARIA DA 5 BAR (75 PSI) A 8 BAR (120 PSI). QUANDO L'ARIA ENTRA NEL CIRCUITO IL PISTONE PNEUMATICO ESEGUE UNA CORSA AZIONANDO IL PISTONCINO IDRAULICO CHE INVIA UNA PREDETERMINATA QUANTITA' DI LUBRIFICANTE ALL' USCITA. QUANDO L'ARIA VIENE TOLTA IL PISTONE TORNA INDIETRO TRAMITE UNA MOLLA, RIEMPIENDO LA CAMERA DI DOSAGGIO ED E' PRONTO PER UNA NUOVA CORSA.

LA FREQUENZA PUO' ESSERE REGOLATA DA 3 COLPI AL SECONDO A 1 AL MINUTO ATTRAVERSO IL GENERATORE DI FREQUENZA E QUESTI VALORI POSSONO CAMBIARE IN BASE AL TIPO DI LUBRIFICANTE UTILIZZATO E ALLA PRESSIONE DELL'ARIA.

LA PORTATA PER CORSA VIENE REGOLATA PER MEZZO DEL POMOLO DA 0 MM<sup>3</sup> A 41 MM<sup>3</sup>

WHEN THE COMPRESSED AIR AT A PRESSURE OF BETWEEN 5 (75 PSI) AND 10 (150 PSI) BAR IS PASSED TO THE PUMP IT ACTS ON THE TOP FACE OF THE PISTON. THE PISTON THEN OPERATES AND A PRECISE SET AMOUNT OF LUBRICANT IS DELIVERED THROUGH THE OUTLET TO THE DELIVERY PORT AND ALONG THE CAPILLARY TUBE. THE AIR IS THEN EXHAUSTED THE PISTON RE-SEATS UNDER SPRING PRESSURE AND THE METERING CHAMBER REFILLS WITH LUBRICANT. THE PUMP IS NOW RESET FOR ANOTHER DELIVERY CYCLE. THE STROKES PER MINUTE CAN BE ADJUSTED BETWEEN 3 EACH SECOND TO 1 EACH MINUTE VIA THE FREQUENCY GENERATOR BUT THESE CAN VARY SLIGHTLY DUE TO THE LUBRICANT USED AND THE AIR PRESSURE

THE LUBRICANT DISCHARGE CAN ALSO BE ADJUSTED BY MEANS OF THE PUMPS MANUAL RATCHET ADJUSTER TO GIVE A DISCHARGE BETWEEN 0 MM<sup>3</sup> AND 41 MM<sup>3</sup> PER STROKE.



A70.093463

## REGOLAZIONE DELLA PORTATA DEL CICLO

RUOTARE IL POMOLO IN SENSO ORARIO PER RIDURRE LA QUANTITA' DI OLIO ED IN SENSO ANTIORARIO PER INCREMENTARLA.

## HOW TO ADJUST THE DISCHARGE PER STROKE

TURNING THE ADJUSTER CLOCKWISE WILL DECREASE THE PUMP DISCHARGE AND TURNING THE ADJUSTER ANTI-CLOCKWISE WILL INCREASE THE PUMP DISCHARGE.

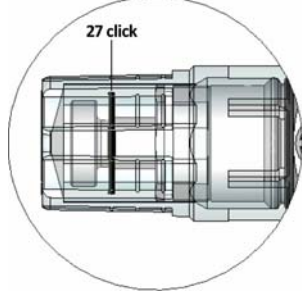
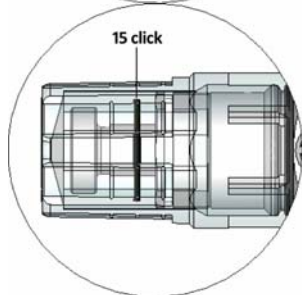
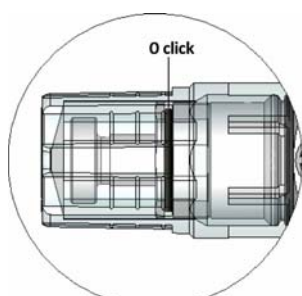
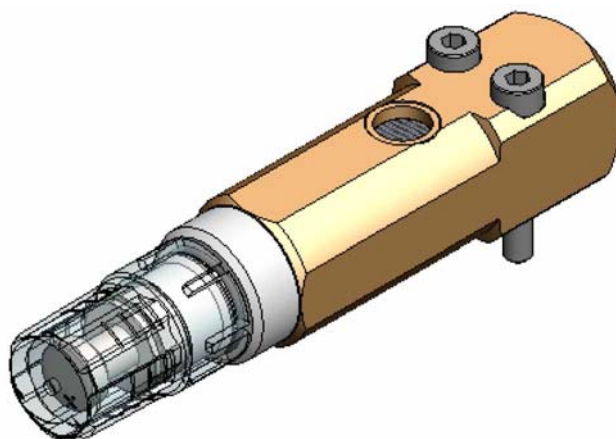

SCATTI <i>INCREMENTS</i>	PORTATA / CICLO <i>DISCHARGE / CYCLE</i>
CLICK 0	39,00 mm <sup>3</sup>
CLICK 1	37,23 mm <sup>3</sup>
CLICK 2	35,47 mm <sup>3</sup>
CLICK 3	33,70 mm <sup>3</sup>
CLICK 4	31,93 mm <sup>3</sup>
CLICK 5	30,16 mm <sup>3</sup>
CLICK 6	28,40 mm <sup>3</sup>
CLICK 7	26,63 mm <sup>3</sup>
CLICK 8	24,86 mm <sup>3</sup>
CLICK 9	23,10 mm <sup>3</sup>
CLICK 10	21,33 mm <sup>3</sup>
CLICK 11	19,56 mm <sup>3</sup>
CLICK 12	17,79 mm <sup>3</sup>
CLICK 13	16,03 mm <sup>3</sup>
CLICK 14	14,26 mm <sup>3</sup>
CLICK 15	12,49 mm <sup>3</sup>
CLICK 16	10,73 mm <sup>3</sup>
CLICK 17	8,96 mm <sup>3</sup>
CLICK 18	7,19 mm <sup>3</sup>
CLICK 19	5,42 mm <sup>3</sup>
CLICK 20	3,66 mm <sup>3</sup>
CLICK 21	1,89 mm <sup>3</sup>
CLICK 22	0,12 mm <sup>3</sup>
CLICK 23	0,00 mm <sup>3</sup>
CLICK 24	0,00 mm <sup>3</sup>
CLICK 25	0,00 mm <sup>3</sup>
CLICK 26	0,00 mm <sup>3</sup>
CLICK 27	0,00 mm <sup>3</sup>





## IMPOSTAZIONE DEI CICLI DEL GENERATORE DI FREQUENZA CON ARIA A 6 BAR (90 PSI)

## HOW TO ADJUST THE FREQUENCY GENERATOR WITH AIR AT 6 BAR (90 PSI)

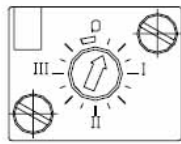

66 CICLI / MINUTO  
66 STROKES / MINUTE

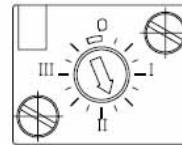

5 CICLI / MINUTO  
5 STROKES / MINUTE

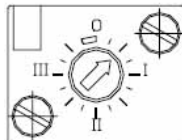

37 CICLI / MINUTO  
37 STROKES / MINUTE

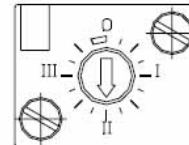

4 CICLI / MINUTO  
4 STROKES / MINUTE

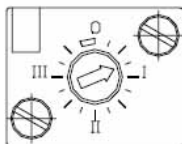

21 CICLI / MINUTO  
21 STROKES / MINUTE

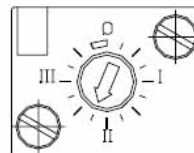

3 CICLI / MINUTO  
3 STROKES / MINUTE

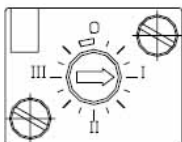

13 CICLI / MINUTO  
13 STROKES / MINUTE

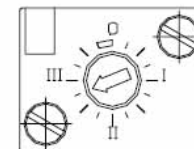

2 CICLI / MINUTO  
2 STROKES / MINUTE

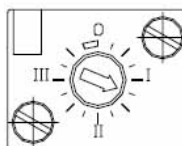

10 CICLI / MINUTO  
10 STROKES / MINUTE

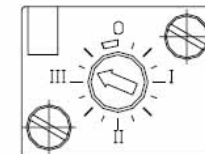

1 CICLO / MINUTO  
1 STROKE / MINUTE

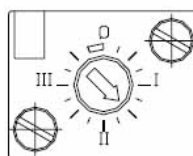

6 CICLI / MINUTO  
6 STROKES / MINUTE

CON UNA PRESSIONE A 5 BAR (75 PSI) I VALORI DEVONO ESSERE INCREMENTATI DEL 7%

CON UNA PRESSIONE A 7 BAR (105 PSI) I VALORI DEVONO ESSERE RIDOTTI DEL 4%

CON UNA PRESSIONE A 8 BAR (120 PSI) I VALORI DEVONO ESSERE RIDOTTI DELL' 8%

WITH THE AIR PRESSURE 5 BAR (75 PSI) THE VALUES HAVE TO BE INCREASED OF ABOUT 7%

WITH THE AIR PRESSURE 7 BAR (105 PSI) THE VALUES HAVE TO BE DECREASED OF ABOUT 4%

WITH THE AIR PRESSURE 8 BAR (120 PSI) THE VALUES HAVE TO BE DECREASED OF ABOUT 8%



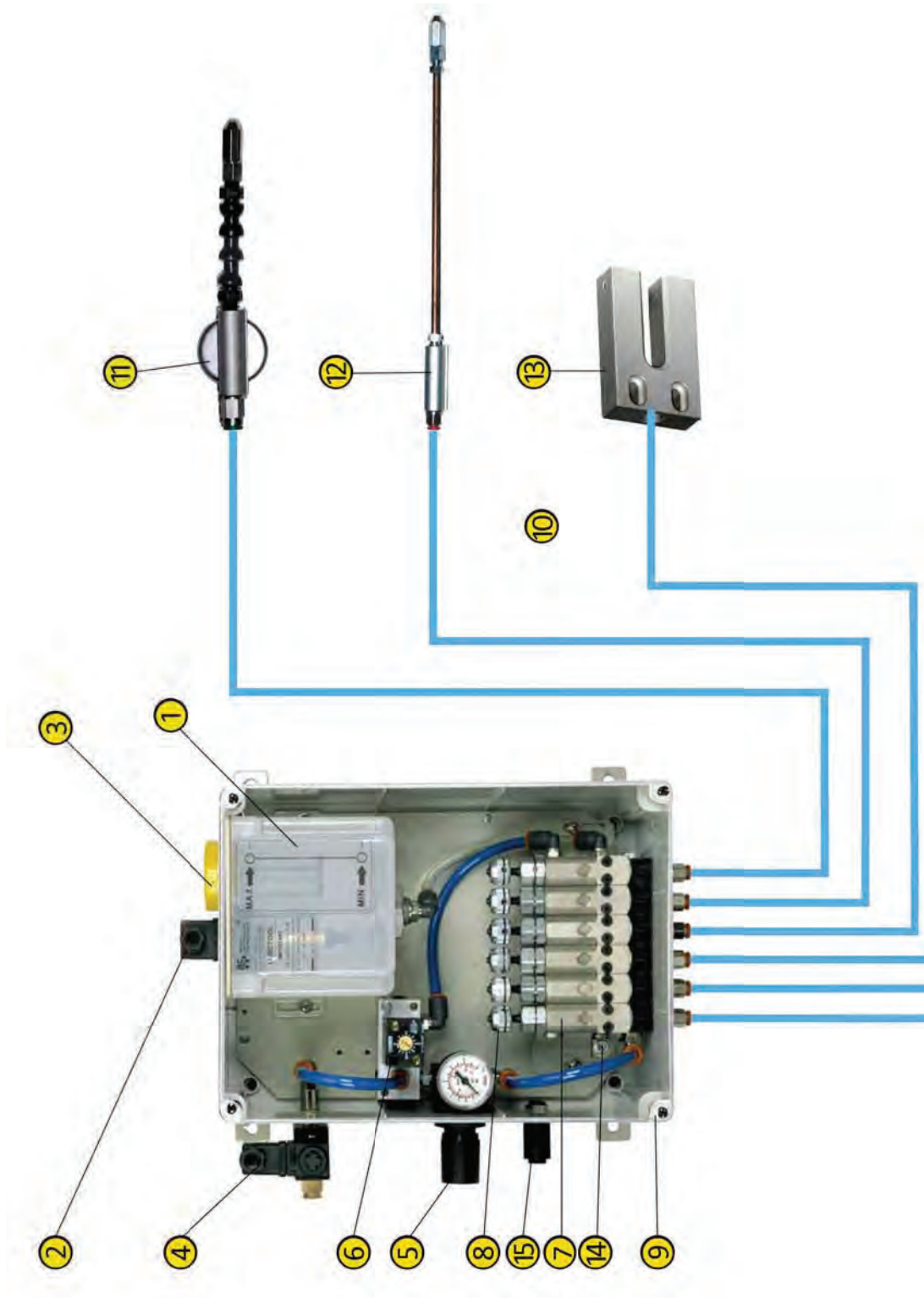

## CARATTERISTICHE E DESCRIZIONE COMPONENTI

**1.SERBATOIO:** CAPACITA' 1.2 L , 2.2 L O 3,6 L IN NYLON SEMITRASPARENTE E RESISTENTE AGLI URTI

**2.MINIMO LIVELLO ELETTRICO:** IL CONTATTO CHIUDE QUANDO IL SERBATOIO SI SVUOTA

**3.TAPPO RIEMPIMENTO:** PER RIEMPIRE DI OLIO IL SERBATOIO

**4.ALIMENTAZIONE D'ARIA:** L'ARIA NEL SISTEMA VIENE INVIATA MEDIANTE UNA ELETTROVALVOLA CON BOBINA DA 24 V DC, 24 V AC, 115 V AC O 230 V AC. L'ARIA DOVRA' AVERE UNA PRESSIONE NON INFERIORE AI 5 BAR (75 PSI) E NON SUPERIORE A 8 BAR (120 PSI). PER EVITARE CHE PARTICELLE O ACQUA ENTRINO NEL SISTEMA E' NECESSARIO UTILIZZARE UN FILTRO DEUMIDIFICATORE DA 5 MICRON

**5.RIDUTTORE CON MANOMETRO:** REGOLA IL FLUSSO DELL'ARIA DA INVIARE AGLI UGELLI. RUOTANDOLO IN SENSO ORARIO AUMENTA L'ARIA E LA DIMINUISCE RUOTANDOLO IN SENSO ANTIORARIO. L'ARIA DOVRA' AVERE UNA PRESSIONE NON INFERIORE AI 0.5 BAR (8 PSI) E NON SUPERIORE AI 3 BAR (45 PSI). NOI SUGGERIAMO 1.5 BAR (22 PSI)

**6.GENERATORE DI FREQUENZA:** QUESTA VALVOLA CONTROLLA LA FREQUENZA DEI CICLI DELLA POMPA. PER AUMENTARE LA FREQUENZA DEI CICLI DELLA POMPA BISOGNA RUOTARE LA VITE DI REGOLAZIONE IN SENSO ANTIORARIO.

**7.POMPA PNEUMATICA:** OGNI CORSA FORNISCE UNA ESATTA QUANTITA' DI LUBRIFICANTE ALL'USCITA

**8.REGOLAZIONE DELLA PORTATA:** I POMOLI REGOLANO LA PORTATA DEL LUBRIFICANTE CHE VIENE FORNITA AD OGNI CORSA DELLA POMPA (REGOLABILE DA 0 MM<sup>3</sup> A 41 MM<sup>3</sup> /CORSA).

**9.CONTENITORE:** IN PLASTICA, RESISTENTE AGLI URTI

**10.TUBAZIONI DI MANDATA COASSIALI:** PER INVIARE OLIO SEPARATO DALL'ARIA AGLI UGELLI

**11.UGELLO COMPLETO DI LOC-LINE CON BASE MAGNETICA**

**12.UGELLO COMPLETO DI TUBAZIONE RIGIDA CON BASE FISSA**

**13. UGELLO A SELLA**

**14.DRENAGGIO ARIA:** PER SPURGARE L'ARIA DALL'OLIO

**15.FILTRO SCARICO ARIA**

## INFORMATION AND OPERATING INSTRUCTIONS

**1.LIQUID RESERVOIR:** SEMITRSPARENT, NYLON IMPACT RESISTANT HAS A CAPACITY OF 1.2 L, 2.2 L OR 3.6 L

**2.LOW LEVEL SWITCH:** THE CONTACT CLOSE WHEN THE RESERVOIR IS EMPTY.

**3.FILLER CUP:** TO RE-FILL OIL IN THE RESERVOIR.

**4.AIR SUPPLY:** A SOLENOID VALVE WITH A COIL 24 V DC, 24 V AC, 115 V AC OR 230 V AC SUPPLY THE AIR IN THE SYSTEM. AIR PRESSURE SHOULD BE MIN 5 BAR (75 PSI) MAX 8 BAR (120 PSI). VERY IMPORTANT IS TO INSTALL A STANDARD PARTICLE FILTER (5 MICRON) TO ELIMINATE PARTICLES AND WATER FROM ENTERING THE SYSTEM. IF THERE IS PROBLEM WITH OIL IN THE AIR SYSTEM, WE SUGGEST RUNNING A COALESCING FILTER IN TANDEM WITH THE PARTICLE AIR FILTER.

**5.AIR REGULATOR WITH GAUGE:** THIS SWITCH ALLOWS THE FLOW OF AIR TO GO IN THE NOZZLES. TURN SWITCH CLOCKWISE TO TURN AIR ON, AND COUNTER-CLOCKWISE TO TURN AIR OFF. THE AIR PRESSURE HAS TO BE FROM 0.5 BAR (8 PSI) TO 3 BAR (45 PSI). WE SUGGEST 1.5 BAR (22 PSI).

**6.FREQUENCY GENERATOR:** THIS VALVE CONTROLS THE FREQUENCY AT WITCH THE PUMP CYCLE. TO INCREASE THE SPEED OF THE PUMPS, TURN SCREWDRIVER ADJUSTMENT COUNTER-CLOCKWISE.

**7.PNEUMATIC PUMP:** EACH STROKE GIVE AN EXACT AMOUNT OF OIL TO THE OUTLET.

**8.OIL FLOW ADJUSTMENT:** THE MANUAL RATCHETS REGULATE THE AMOUNT OF LUBRICANT THAT IS SUPPLIED WITH EACH STROKE OF THE PUMP (ADJUSTABLE FROM 0 MM<sup>3</sup> TO 41 MM<sup>3</sup> /STROKE).

**9.BOX:** DURABLE IMPACT-RESISTANT LOCKING PLASTIC BOX.

**10.COAXIAL FEEDING LINE:** TO SUPPLY OIL SEPARATE FROM AIR TO THE NOZZLE.

**11.LOC-LINE MAGNETIC BASE NOZZLE**

**12.STEEL FIXED BASE NOZZLE**

**13. SAW SADDLE NOZZLE**

**14.AIR DRAIN:** TO PURGE AIR FROM THE OIL SYSTEM

**15.STRAINER EXHAUST AIR**



## UNITA' LUBETOOL UCGF, UCGF-SE, AGGF E AGGF-SE CON GENERATORE DI FREQUENZA

IL CIRCUITO PNEUMATICO INTERNO SI DIRAMA IN CORRISPONDENZA DEL GENERATORE DI FREQUENZA. DURANTE IL TEMPO DI ATTIVAZIONE DELL'ELETTROVALVOLA SI AVRA' UN FLUSSO COSTANTE DI ARIA AI TUBI DI PROIEZIONE, MENTRE IL GENERATORE DI FREQUENZA REGOLERA' LE CORSE DELLA MICROPOMPA.

L'ELETTROVALVOLA DEVE ESSERE ATTIVATA PRIMA CHE L'UTENSILE INIZI A LAVORARE E DEVE ESSERE CHIUSA QUANDO L'UTENSILE FINISCE.

## UNITA' LUBETOOL UCSG, UCSG-SE, AGSG E AGSG-SE SENZA GENERATORE DI FREQUENZA

QUESTE UNITA' SONO DESTINATE AD IMPIEGHI DOVE E' RICHIESTO UN CICLO DI INTERVENTO PROGRAMMATO DA UN COMANDO ESTERNO DELLA MACCHINA. AD OGNI ATTIVAZIONE DELL'ELETTROVALVOLA CORRISPONDERA' L'INVIO DEL FLUSSO DI ARIA NELLE TUBAZIONI DI MANDATA E SIMULTANEAMENTE UN EROGAZIONE DEL LUBRIFICANTE DALLE MICROPOMPE. QUESTA OPERAZIONE PUO' ESSERE RIPETUTA PIU' VOLTE INTERPONENDO UNA PAUSA PER LA RICARICA DEL LUBRIFICANTE DI ALMENO 0.5 SECONDI.

## LUBETOOL UCGF, UCGF-SE, AGGF AND AGGF-SE WITH FREQUENCY GENERATOR

THE INSIDE PNEUMATIC CIRCUIT GOES DIRECT TO THE AIR FEEDING LINES AND TO THE PUMPS (THROUGH THE FREQUENCY GENERATOR). WHEN THE SOLENOID VALVE IS ENERGIZED THE PUMPS CAN CYCLE (ADJUSTABLE WITH THE FREQUENCY GENERATOR) AND AIR IS SENT CONTINUOUSLY TO THE TOOL. THE SOLENOID VALVE HAS TO BE ENERGIZED BEFORE THE TOOL WILL BEGIN TO MACHINE AND SHUT DOWN WHEN THE TOOL WILL FINISH TO MACHINE.

## LUBETOOL UCSG, UCSG-SE, AGSG AND AGSG-SE WITHOUT FREQUENCY GENERATOR

THE UCSG TYPES NEED AN EXTERNAL DRIVE TO ADJUST THE FREQUENCY AT WHICH THE PUMPS CYCLE. THE INSIDE PNEUMATIC CIRCUIT GOES DIRECT TO THE AIR FEEDING LINES AND TO THE PUMPS. WHEN THE SOLENOID VALVE IS ENERGIZED THE PUMPS CAN CYCLE 1 TIME AND AIR IS SENT CONTINUOUSLY TO THE TOOLS. TO HAVE ANOTHER PUMP CYCLE THE SOLENOID VALVE HAVE TO BE DEENERGIZED AND AFTER ENERGIZED (MINIMUM PAUSE TIME IS 0.5 SECONDS).

### CARATTERISTICHE

PORTATA	DA 0 MM <sup>3</sup> A 41 MM <sup>3</sup>
POMPE	DA 1 A 6
ELETTROVALVOLA	24 V DC – 24 V AC – 115 V AC – 230 V AC
CORSE	DA 3 AL SECONDO A 1 AL MINUTO
SERBATOIO	1.2 L
LUBRIFICANTE	OLIO MAX 800 cSt 40 °C
LIVELLO ELETTRICO	1 A 250 V AC – 220 V DC – 50 W
PRESSIONE ARIA	DA 4 BAR A 8 BAR
CONSUMO ARIA PER PUNTO A 6 BAR	MIN: 60 L/M – MAX 100 L/M

### FEATURES

DISCHARGE	FROM 0 MM <sup>3</sup> TO 41 MM <sup>3</sup>
PUMPS	FROM 1 TO 6
SOLENOID VALVE	24 V DC – 24 V AC – 115 V AC – 230 V AC
STROKES	FROM 3 /SECOND TO 1 / MINUTE
RESERVOIR	1.2 L
LUBRICANT	OIL MAX 800 cSt 40 °C
LOW LEVEL SWITCH	1 A 250 V AC – 220 V DC – 50 W
AIR PRESSURE	FROM 4 BAR TO 8 BAR
AIR CONSUME AT 6 BAR/POINT	MIN: 60 L/M – MAX 100 L/M





## UCGF

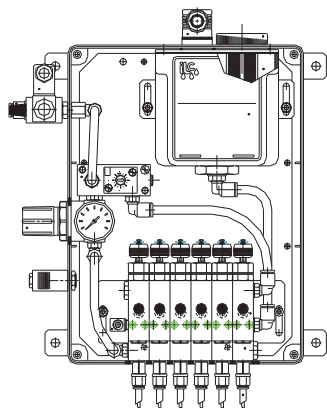

### L'UNITA' E' FORNITA COMPLETA DI:

- SERBATOIO 1.2 L
- LIVELLO ELETTRICO: 1 A 250 V AC 200 V DC 50 W
- POMPE DA 1 A 6
- 5 M TUBO COASSIALE PER OGNI USCITA (6 MM – 2.5 MM)

SCATOLA DI PROTEZIONE ABS PORTA TRASPARENTE

ELETTROVALVOLA 24 V DC – 24 V AC – 115 V AC O 230 V AC  
LA TENSIONE DEVE ESSERE AGGIUNTA AL CODICE. ESEMPIO  
70.000.0.24VDC

REGOLATORE D'ARIA + MANOMETRO

GENERATORE DI FREQUENZA

### THE UNIT IS SUPPLIED COMPLETE OF:

- RESERVOIR 1.2 L
- LOW LEVEL SWITCH: 1 A 250 V AC 200 V DC 50 W
- PUMPS FROM 1 TO 6
- 5 M COAXIAL FEEDING LINES FOR EACH OUTLET (6 MM – 2.5 MM)

BOX ABS WITH TRANSPARENT FRONT DOOR

SOLENOID VALVE 24 V DC – 24 V AC – 115 V AC OR 230 V AC  
THE VOLTAGE HAS TO BE ADD TO THE CODE. EXAMPLE  
70.000.0.24VDC

AIR REGULATOR + PRESSURE GAUGE

FREQUENCY GENERATOR

### CODICI DI ORDINAZIONE – CODES FOR ORDER

CODICE CODE	MODELLO TYPE	NUMERO DI POMPE PUMPS NUMBER
70.000.0	UCGF – 1	1
70.000.1	UCGF – 2	2
70.000.2	UCGF – 3	3
70.000.3	UCGF – 4	4
70.000.4	UCGF – 5	5
70.000.5	UCGF – 6	6

### CODICI PER ORDINARE BOBINE DELL'ELETTROVALVOLA – CODES TO ORDER SOLENOID VALVE COILS

14.660.1.R	14.660.2.R	14.660.3.R	14.660.4.R
24 V DC	115 V AC	230 V AC	24 V AC



UCGF-SE

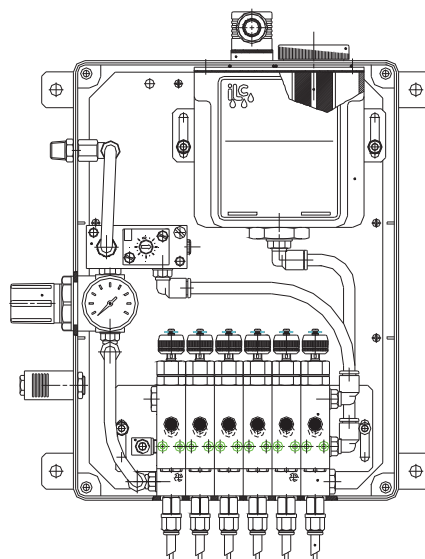

**L'UNITA' E' FORNITA COMPLETA DI:**

- SERBATOIO 1.2 L
- LIVELLO ELETTRICO: 1 A 250 V AC 200 V DC 50 W
- POMPE DA 1 A 6
- 5 M TUBO COASSIALE PER OGNI USCITA (6 MM – 2.5 MM)
- SCATOLA DI PROTEZIONE ABS PORTA TRASPARENTE
- REGOLATORE D'ARIA + MANOMETRO
- GENERATORE DI FREQUENZA

**THE UNIT IS SUPPLIED COMPLETE OF:**

- RESERVOIR 1.2 L
- LOW LEVEL SWITCH: 1 A 250 V AC 200 V DC 50 W
- PUMPS FROM 1 TO 6
- 5 M COAXIAL FEEDING LINES FOR EACH OUTLET (6 MM – 2.5 MM)
- BOX ABS WITH TRANSPARENT FRONT DOOR
- AIR REGULATOR + PRESSURE GAUGE
- FREQUENCY GENERATOR

**CODICI DI ORDINAZIONE – CODES FOR ORDER**

CODICE CODE	MODELLO TYPE	NUMERO DI POMPE PUMPS NUMBER
70.009.0	UCGF – SE - 1	1
70.009.1	UCGF – SE - 2	2
70.009.2	UCGF – SE - 3	3
70.009.3	UCGF – SE - 4	4
70.009.4	UCGF – SE - 5	5
70.009.5	UCGF – SE - 6	6





## UCSG

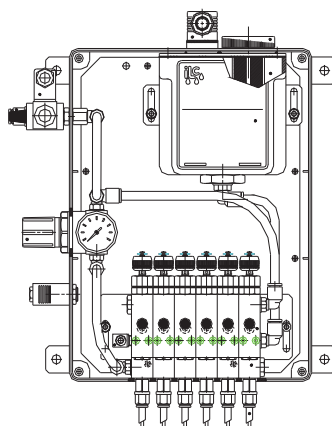

### L'UNITA' E' FORNITA COMPLETA DI:

- SERBATOIO 1.2 L
- LIVELLO ELETTRICO: 1 A 250 V AC 200 V DC 50 W
- POMPE DA 1 A 6
- 5 M TUBO COASSIALE PER OGNI USCITA (6 MM – 2.5 MM)
- SCATOLA DI PROTEZIONE ABS PORTA TRASPARENTE
- ELETTRIVALVOLA 24 V DC – 24 V AC – 115 V AC O 230 V AC  
LA TENSIONE DEVE ESSERE AGGIUNTA AL CODICE. ESEMPIO  
70.001.0.24VDC
- REGOLATORE D'ARIA + MANOMETRO

### THE UNIT IS SUPPLIED COMPLETE OF:

- RESERVOIR 1.2 L
- LOW LEVEL SWITCH: 1 A 250 V AC 200 V DC 50 W
- PUMPS FROM 1 TO 6
- 5 M COAXIAL FEEDING LINES FOR EACH OUTLET (6 MM – 2.5 MM)
- BOX ABS WITH TRANSPARENT FRONT DOOR
- SOLENOID VALVE 24 V DC – 24 V AC – 115 V AC OR 230 V AC  
THE VOLTAGE HAS TO BE ADD TO THE CODE. EXAMPLE  
70.001.0.24VDC
- AIR REGULATOR + PRESSURE GAUGE

### CODICI DI ORDINAZIONE – CODES FOR ORDER

CODICE CODE	MODELLO TYPE	NUMERO DI POMPE PUMPS NUMBER
70.001.0	UCSG - 1	1
70.001.1	UCSG – 2	2
70.001.2	UCSG – 3	3
70.001.3	UCSG – 4	4
70.001.4	UCSG – 5	5
70.001.5	UCSG - 6	6

### CODICI PER ORDINARE BOBINE DELL'ELETTRIVALVOLA – CODES TO ORDER SOLENOID VALVE COILS

14.660.1.R	14.660.2.R	14.660.3.R	14.660.4.R
24 V DC	115 V AC	230 V AC	24 V AC





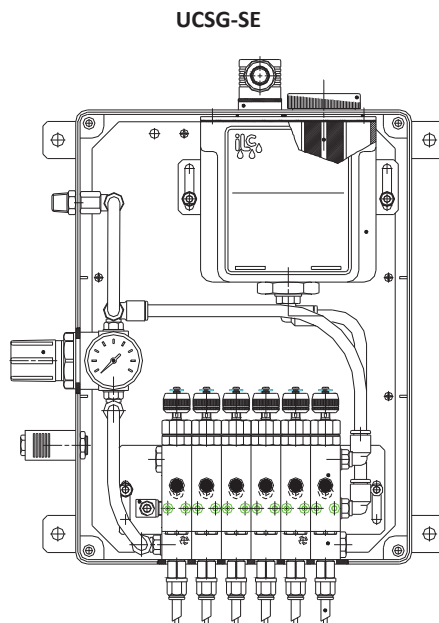

**L'UNITA' E' FORNITA COMPLETA DI:**

- SERBATOIO 1.2 L
- LIVELLO ELETTRICO: 1 A 250 V AC 200 V DC 50 W
- POMPE DA 1 A 6
- 5 M TUBO COASSIALE PER OGNI USCITA (6 MM – 2.5 MM)
- SCATOLA DI PROTEZIONE ABS PORTA TRASPARENTE
- REGOLATORE D'ARIA + MANOMETRO

**THE UNIT IS SUPPLIED COMPLETE OF:**

- RESERVOIR 1.2 L
- LOW LEVEL SWITCH: 1 A 250 V AC 200 V DC 50 W
- PUMPS FROM 1 TO 6
- 5 M COAXIAL FEEDING LINES FOR EACH OUTLET (6 MM – 2.5 MM)
- BOX ABS WITH TRANSPARENT FRONT DOOR
- AIR REGULATOR + PRESSURE GAUGE

**CODICI DI ORDINAZIONE – CODES FOR ORDER**

CODICE CODE	MODELLO TYPE	NUMERO DI POMPE PUMPS NUMBER
70.010.0	UCSG – SE - 1	1
70.010.1	UCSG – SE - 2	2
70.010.2	UCSG – SE - 3	3
70.010.3	UCSG – SE - 4	4
70.010.4	UCSG – SE - 5	5
70.010.5	UCSG – SE - 6	6



**DIMENSIONI D'INGOMBRO UCSG**

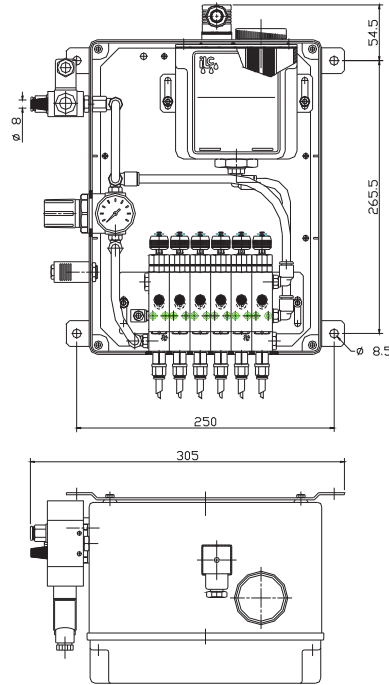

**OVERALL DIMENSION UCSG**

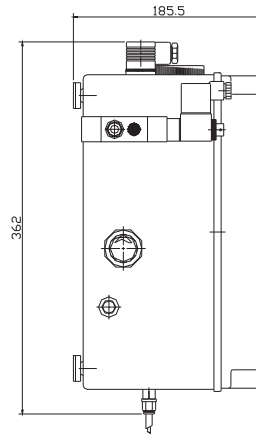

**DIMENSIONI D'INGOMBRO UCSG - SE**

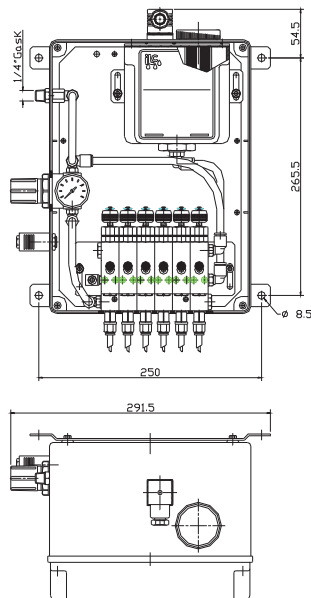

**OVERALL DIMENSION UCSG - SE**

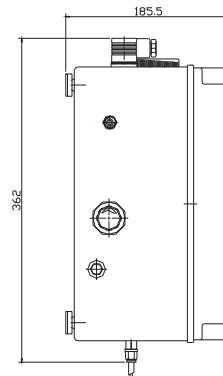

## AGGF

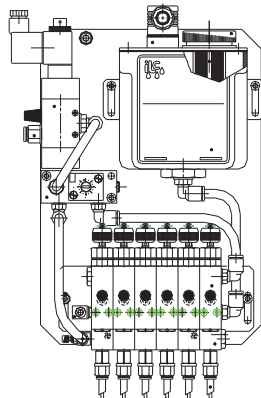

### L'UNITA' E' FORNITA COMPLETA DI:

- SERBATOIO 1.2 L
- LIVELLO ELETTRICO: 1 A 250 V AC 200 V DC 50 W
- POMPE DA 1 A 6
- 5 M TUBO COASSIALE PER OGNI USCITA (6 MM – 2.5 MM)

ELETTROVALVOLA 24 V DC – 24 V AC – 115 V AC O 230 V AC  
LA TENSIONE DEVE ESSERE AGGIUNTA AL CODICE. ESEMPIO  
70.006.0.24VDC

REGOLATORE D'ARIA

GENERATORE DI FREQUENZA

### THE UNIT IS SUPPLIED COMPLETE OF:

- RESERVOIR 1.2 L
- LOW LEVEL SWITCH: 1 A 250 V AC 200 V DC 50 W
- PUMPS FROM 1 TO 6
- 5 M COAXIAL FEEDING LINES FOR EACH OUTLET (6 MM – 2.5 MM)

SOLENOID VALVE 24 V DC – 24 V AC – 115 V AC OR 230 V AC  
THE VOLTAGE HAS TO BE ADD TO THE CODE. EXAMPLE  
70.006.0.24VDC

AIR REGULATOR

FREQUENCY GENERATOR

### CODICI DI ORDINAZIONE – CODES FOR ORDER

CODICE CODE	MODELLO TYPE	NUMERO DI POMPE PUMPS NUMBER
70.006.0	AGGF - 1	1
70.006.1	AGGF - 2	2
70.006.2	AGGF - 3	3
70.006.3	AGGF - 4	4
70.006.4	AGGF - 5	5
70.006.5	AGGF - 6	6

### CODICI PER ORDINARE BOBINE DELL'ELETTRVALVOLA – CODES TO ORDER SOLENOID VALVE COILS

14.660.1.R	14.660.2.R	14.660.3.R	14.660.4.R
24 V DC	115 V AC	230 V AC	24 V AC



**AGGF - SE**

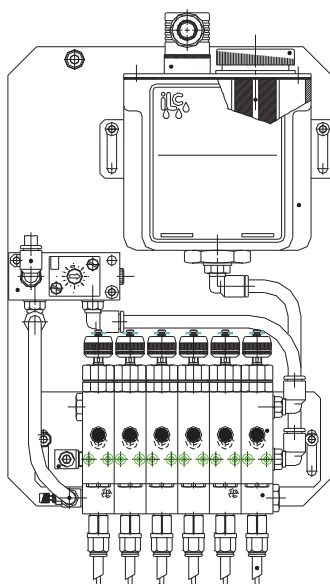

**L'UNITA' E' FORNITA COMPLETA DI:**

- SERBATOIO 1.2 L
- LIVELLO ELETTRICO: 1 A 250 V AC 200 V DC 50 W
- POMPE DA 1 A 6
- 5 M TUBO COASSIALE PER OGNI USCITA (6 MM – 2.5 MM)
- REGOLATORE D'ARIA
- GENERATORE FI FREQUENZA

**THE UNIT IS SUPPLIED COMPLETE OF:**

- RESERVOIR 1.2 L
- LOW LEVEL SWITCH: 1 A 250 V AC 200 V DC 50 W
- PUMPS FROM 1 TO 6
- 5 M COAXIAL FEEDING LINES FOR EACH OUTLET (6 MM – 2.5 MM)
- AIR REGULATOR
- FREQUENCY GENERATOR

**CODICI DI ORDINAZIONE – CODES FOR ORDER**

CODICE CODE	MODELLO TYPE	NUMERO DI POMPE PUMPS NUMBER
70.002.0	AGGF – SE - 1	1
70.002.1	AGGF – SE - 2	2
70.002.2	AGGF – SE - 3	3
70.002.3	AGGF – SE - 4	4
70.002.4	AGGF – SE - 5	5
70.002.5	AGGF – SE - 6	6



**DIMENSIONI D'INGOMBRO AGGF**

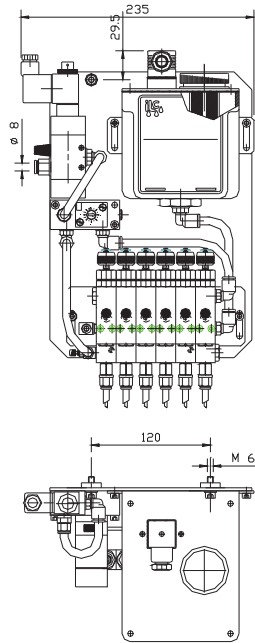

**OVERALL DIMENSION AGGF**

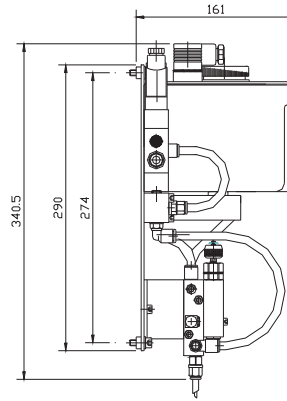

**DIMENSIONI D'INGOMBRO AGGF - SE**

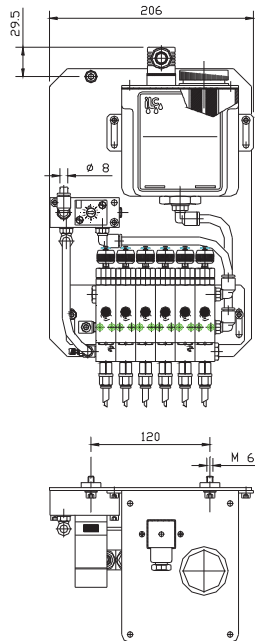

**OVERALL DIMENSION AGGF - SE**

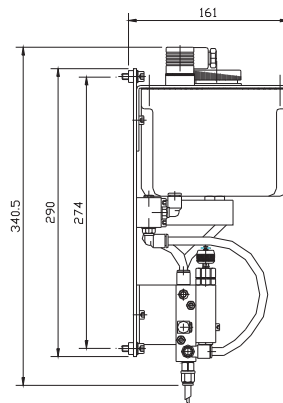



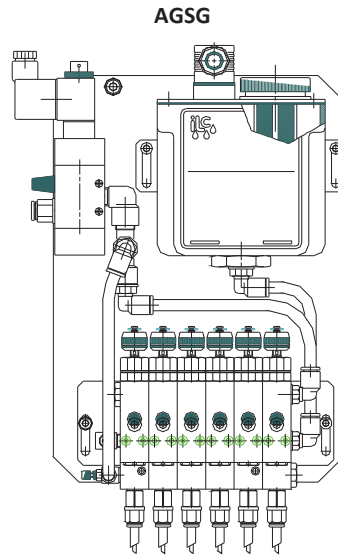

**L'UNITA' E' FORNITA COMPLETA DI:**

- SERBATOIO 1.2 L
- LIVELLO ELETTRICO: 1 A 250 V AC 200 V DC 50 W
- POMPE DA 1 A 6
- 5 M TUBO COASSIALE PER OGNI USCITA (6 MM – 2.5 MM)
- ELETTROVALVOLA 24 V DC – 24 V AC – 115 V AC O 230 V AC  
LA TENSIONE DEVE ESSERE AGGIUNTA AL CODICE. ESEMPIO  
70.018.0.24VDC
- REGOLATORE D'ARIA

**THE UNIT IS SUPPLIED COMPLETE OF:**

- RESERVOIR 1.2 L
- LOW LEVEL SWITCH: 1 A 250 V AC 200 V DC 50 W
- PUMPS FROM 1 TO 6
- 5 M COAXIAL FEEDING LINES FOR EACH OUTLET (6 MM – 2.5 MM)
- SOLENOID VALVE 24 V DC – 24 V AC – 115 V AC OR 230 V AC  
THE VOLTAGE HAS TO BE ADD TO THE CODE. EXAMPLE  
70.018.0.24VDC
- AIR REGULATOR

**CODICI DI ORDINAZIONE – CODES FOR ORDER**

CODICE CODE	MODELLO TYPE	NUMERO DI POMPE PUMPS NUMBER
70.018.0	AGSG – 1	1
70.018.1	AGSG – 2	2
70.018.2	AGSG – 3	3
70.018.3	AGSG – 4	4
70.018.4	AGSG – 5	5
70.018.5	AGSG – 6	6

**CODICI PER ORDINARE BOBINE DELL'ELETTROVALVOLA – CODES TO ORDER SOLENOID VALVE COILS**

14.660.1.R	14.660.2.R	14.660.3.R	14.660.4.R
24 V DC	115 V AC	230 V AC	24 V AC



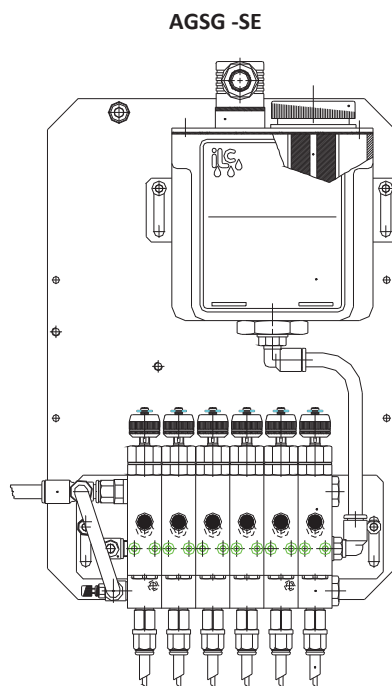

**L'UNITA' E' FORNITA COMPLETA DI:**

- SERBATOIO 1.2 L
- LIVELLO ELETTRICO: 1 A 250 V AC 200 V DC 50 W
- POMPE DA 1 A 6
- 5 M TUBO COASSIALE PER OGNI USCITA (6 MM – 2.5 MM)
- REGOLATORE D'ARIA

**THE UNIT IS SUPPLIED COMPLETE OF:**

- RESERVOIR 1.2 L
- LOW LEVEL SWITCH: 1 A 250 V AC 200 V DC 50 W
- PUMPS FROM 1 TO 6
- 5 M COAXIAL FEEDING LINES FOR EACH OUTLET (6 MM – 2.5 MM)
- AIR REGULATOR

**CODICI DI ORDINAZIONE – CODES FOR ORDER**

CODICE CODE	MODELLO TYPE	NUMERO DI POMPE PUMPS NUMBER
70.003.0	AGSG – SE - 1	1
70.003.1	AGSG – SE - 2	2
70.003.2	AGSG – SE - 3	3
70.003.3	AGSG – SE - 4	4
70.003.4	AGSG – SE - 5	5
70.003.5	AGSG – SE - 6	6





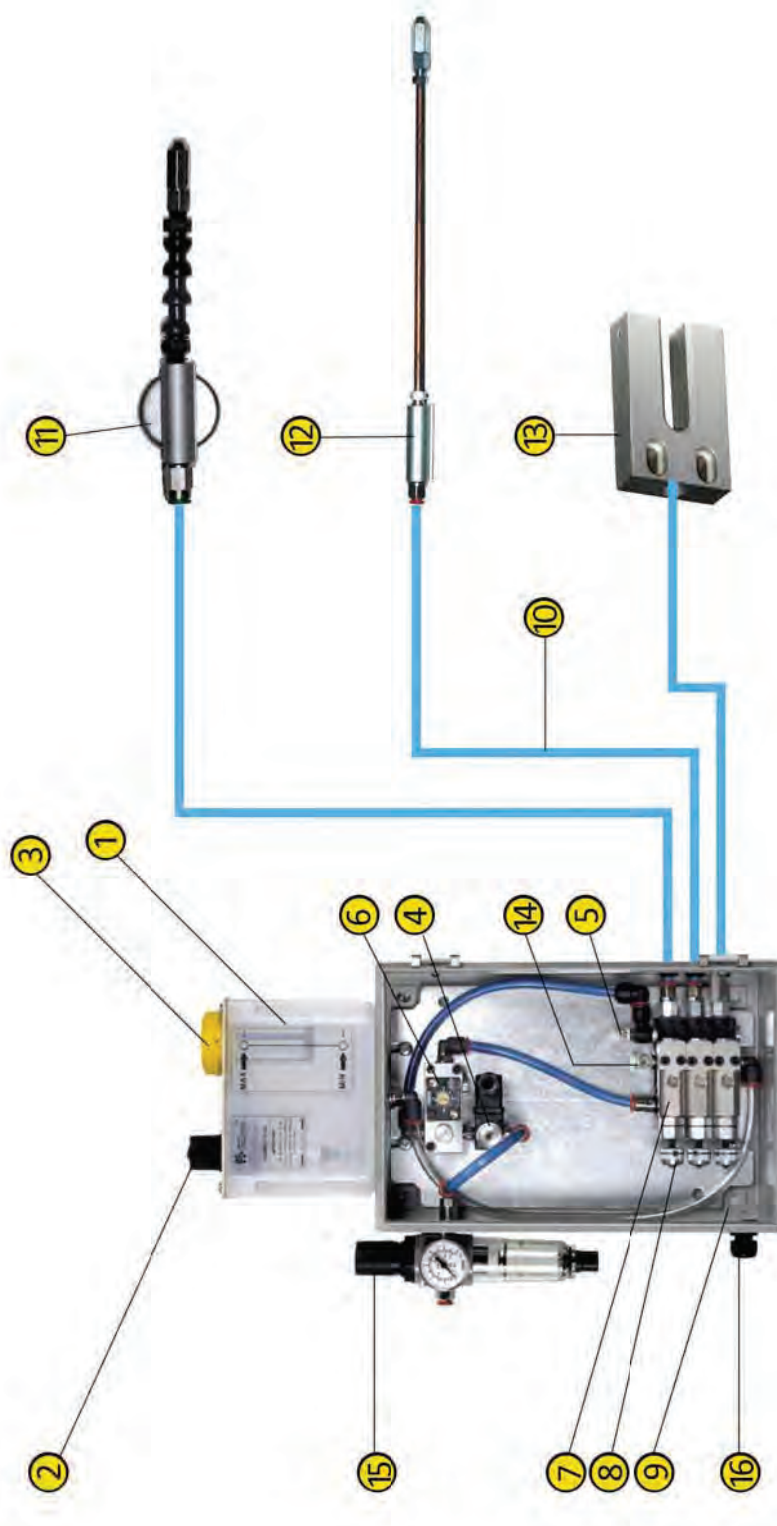

## CARATTERISTICHE E DESCRIZIONE COMPONENTI

**1.SERBATOIO:** CAPACITA' 1.2 L , 2.2 L O 3,6 L IN NYLON SEMITRASPARENTE E RESISTENTE AGLI URTI

**2.MINIMO LIVELLO ELETTRICO:** IL CONTATTO CHIUDE QUANDO IL SERBATOIO SI SVUOTA

**3.TAPPO RIEMPIMENTO:** PER RIEMPIRE DI OLIO IL SERBATOIO

**4.ALIMENTAZIONE D'ARIA:** L'ARIA NEL SISTEMA VIENE INVIATA MEDIANTE UNA ELETTROVALVOLA CON BOBINA DA 24 V DC, 24 V AC, 115 V AC O 230 V AC. L'ARIA DOVRA' AVERE UNA PRESSIONE NON INFERIORE AI 5 BAR (75 PSI) E NON SUPERIORE A 8 BAR (120 PSI). PER EVITARE CHE PARTICELLE O ACQUA ENTRINO NEL SISTEMA E' NECESSARIO UTILIZZARE UN FILTRO DEUMIDIFICATORE DA 5 MICRON

**5.REGOLATORE ARIA:** REGOLA IL FLUSSO DELL'ARIA DA INVIARE AGLI UGELLI. RUOTANDOLO IN SENSO ORARIO AUMENTA L'ARIA E LA DIMINUISCE RUOTANDOLO IN SENSO ANTIORARIO. L'ARIA DOVRA' AVERE UNA PRESSIONE NON INFERIORE AI 0.5 BAR (8 PSI) E NON SUPERIORE AI 3 BAR (45 PSI). NOI SUGGERIAMO 1.5 BAR (22 PSI)

**6.GENERATORE DI FREQUENZA:** QUESTA VALVOLA CONTROLLA LA FREQUENZA DEI CICLI DELLA POMPA. PER AUMENTARE LA FREQUENZA DEI CICLI DELLA POMPA BISOGNA RUOTARE LA VITE DI REGOLAZIONE IN SENSO ANTIORARIO.

**7.POMPA PNEUMATICA:** OGNI CORSA FORNISCE UNA ESATTA QUANTITA' DI LUBRIFICANTE ALL'USCITA

**8.REGOLAZIONE DELLA PORTATA:** I POMOLI REGOLANO LA PORTATA DEL LUBRIFICANTE CHE VIENE FORNITA AD OGNI CORSA DELLA POMPA (REGOLABILE DA 0 MM<sup>3</sup> A 41 MM<sup>3</sup> /CORSA).

**9.CONTENITORE:** CONTENITORE IN METALLO

**10.TUBAZIONI DI MANDATA COASSIALI:** PER INVIARE OLIO SEPARATO DALL'ARIA AGLI UGELLI

**11.UGELLO COMPLETO DI LOC-LINE CON BASE MAGNETICA**

**12.UGELLO COMPLETO DI TUBAZIONE RIGIDA CON BASE FISSA**

**13. UGELLO A SELLA**

**14.DRENAGGIO ARIA:** PER SPURGARE L'ARIA DALL'OLIO

**15.RIDUTTORE CON MANOMETRO**

**16.PRESSACAVO**

## INFORMATION AND OPERATING INSTRUCTIONS

**1.LIQUID RESERVOIR:** SEMITRSPARENT, NYLON IMPACT RESISTANT HAS A CAPACITY OF 1.2 L, 2.2 L OR 3.6 L

**2.LOW LEVEL SWITCH:** THE CONTACT CLOSE WHEN THE RESERVOIR IS EMPTY.

**3.FILLER CUP:** TO RE-FILL OIL IN THE RESERVOIR.

**4.AIR SUPPLY:** A SOLENOID VALVE WITH A COIL 24 V DC, 24 V AC, 115 V AC OR 230 V AC SUPPLY THE AIR IN THE SYSTEM. AIR PRESSURE SHOULD BE MIN 5 BAR (75 PSI) TO MAX 8 BAR (120 PSI). IT IS VERY IMPORTANT TO INSTALL A STANDARD PARTICLE FILTER (5 MICRON) TO ELIMINATE PARTICLES AND WATER FROM ENTERING THE SYSTEM. IF THERE IS PROBLEM WITH OIL IN THE AIR SYSTEM, WE SUGGEST RUNNING A COALESCING FILTER IN TANDEM WITH THE PARTICLE AIR FILTER.

**5.AIR REGULATOR:** THIS SWITCH ALLOWS THE FLOW OF AIR TO GO IN THE NOZZLES. TURN SWITCH CLOCKWISE TO TURN AIR ON, AND COUNTER-CLOCKWISE TO TURN AIR OFF. THE AIR PRESSURE HAS TO BE FROM 0.5 BAR (8 PSI) TO 3 BAR (45 PSI). WE SUGGEST 1.5 BAR (22 PSI).

**6.FREQUENCY GENERATOR:** THIS VALVE CONTROLS THE FREQUENCY AT WHICH THE PUMP CYCLE. TO INCREASE THE SPEED OF THE PUMPS, TURN SCREWDRIVER ADJUSTMENT COUNTER-CLOCKWISE.

**7.PNEUMATIC PUMP:** EACH STROKE GIVE AN EXACT AMOUNT OF OIL TO THE OUTLET.

**8.OIL FLOW ADJUSTMENT:** THE MANUAL RATCHETS REGULATE THE AMOUNT OF LUBRICANT THAT IS SUPPLIED WITH EACH STROKE OF THE PUMP (ADJUSTABLE FROM 0 MM<sup>3</sup> TO 41 MM<sup>3</sup> /STROKE).

**9.BOX:** DURABLE IMPACT-RESISTANT LOCKING METALLIC BOX.

**10.COAXIAL FEEDING LINE:** TO SUPPLY OIL SEPARATE FROM AIR TO THE NOZZLE.

**11.LOC-LINE MAGNETIC BASE NOZZLE**

**12.STEEL FIXED BASE NOZZLE**

**13. SAW SADDLE NOZZLE**

**14.AIR DRAIN:** TO PURGE AIR FROM THE OIL SYSTEM

**15.PRESSURE REDUCER WITH GAUGE**

**16.CABLE GLAND**





**UNITA' LUBETOOL MC-EL-3P-4P-5P-6P-7P, MC-EL-3M-4M-5M-6M-7M, MC-EL-2P E MC-EL-2M**  
SONO FORNITI COMPLETI DI SCATOLA DI PROTEZIONE METALLICA

**LUBETOOL MC-EL-3P-4P-5P-6P-7P, MC-EL-3M-4M-5M-6M-7M, MC-EL-2P E MC-EL-2M**  
THEY ARE SUPPLIED COMPLETE OF METALLIC BOX

CARATTERISTICHE		FEATURES	
PORTATA	DA 0 MM <sup>3</sup> A 41 MM <sup>3</sup>	DISCHARGE	FROM 0 MM <sup>3</sup> TO 41 MM <sup>3</sup>
POMPE	DA 1 A 7	PUMPS	FROM 1 TO 7
ELETTRIVALVOLA	24 V DC – 24 V AC – 115 V AC – 230 V AC	SOLENOID VALVE	24 V DC – 24 V AC – 115 V AC – 230 V AC
CORSE	DA 3 AL SECONDO A 1 AL MINUTO	STROKES	FROM 3 /SECOND TO 1 / MINUTE
SERBATOIO	1.2 L, 2.2 L O 3.6 L	RESERVOIR	1.2 L, 2.2 L OR 3.6 L
LUBRIFICANTE	OLIO MAX 800 cSt 40 °C	LUBRICANT	OIL MAX 800 cSt 40 °C
LIVELLO ELETTRICO	1 A 250 V AC – 220 V DC – 50 W	LOW LEVEL SWITCH	1 A 250 V AC – 220 V DC – 50 W
PRESSIONE ARIA	DA 4 BAR A 8 BAR	AIR PRESSURE	FROM 4 BAR TO 8 BAR
CONSUMO ARIA PER PUNTO A 6 BAR	MIN: 60 L/M – MAX 100 L/M	AIR CONSUME AT 6 BAR/POINT	MIN: 60 L/M – MAX 100 L/M



## MC-EL-3P-4P-5P-6P-7P

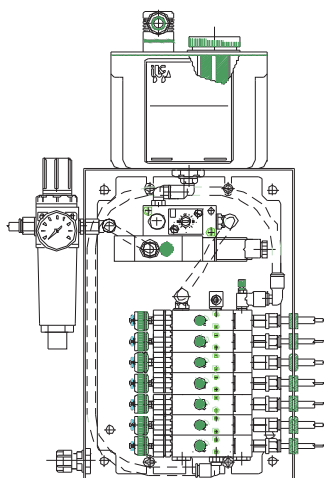

L'UNITA' E' FORNITA COMPLETA DI:	THE UNIT IS SUPPLIED COMPLETE OF:
SERBATOIO 1.2 L O 2.2 L	RESERVOIR 1.2 L OR 2.2 L
LIVELLO ELETTRICO: 1 A 250 V AC 200 V DC 50 W	LOW LEVEL SWITCH: 1 A 250 V AC 200 V DC 50 W
3-4-5-6-7 POMPE	3 -4-5-6-7 PUMPS
5 M TUBO COASSIALE PER OGNI USCITA (6 MM – 2.5 MM)	5 M COAXIAL LINES FOR EACH OUTLET (6 MM – 2.5 MM)
SCATOLA DI PROTEZIONE METALLICA	METALLIC BOX
ELETTROVALVOLA	SOLENOID VALVE
REGOLATORE D'ARIA	AIR REGULATOR
GENERATORE DI FREQUENZA	FREQUENCY GENERATOR
RIDUTTORE + MANOMETRO	AIR REDUCER + GAUGE

### CODICI DI ORDINAZIONE – CODES FOR ORDER

CODICE CODE	MODELLO TYPE	CODICE CODE	MODELLO TYPE
70.050.7	MC-EL-3P-1.2	70.050.7.SL	MC-EL-3P-1.2-SL
70.050.8	MC-EL-3P-2.2	70.050.8.SL	MC-EL-3P-2.2-SL
70.051.3	MC-EL-4P-1.2	70.051.3.SL	MC-EL-4P-1.2-SL
70.051.4	MC-EL-4P-2.2	70.051.4.SL	MC-EL-4P-2.2-SL
70.051.5	MC-EL-5P-1.2	70.051.5.SL	MC-EL-5P-1.2-SL
70.051.6	MC-EL-5P-2.2	70.051.6.SL	MC-EL-5P-2.2-SL
70.051.7	MC-EL-6P-1.2	70.051.7.SL	MC-EL-6P-1.2-SL
70.051.8	MC-EL-6P-2.2	70.051.8.SL	MC-EL-6P-2.2-SL
70.054.0	MC-EL-7P-1.2	70.054.0.SL	MC-EL-7P-1.2-SL
70.054.1	MC-EL-7P-2.2	70.054.1.SL	MC-EL-7P-2.2-SL
SL: L'UNITA' E' FORNITA SENZA LIVELLO ELETTRICO		SL: THE UNIT WILL BE DELIVERED WITHOUT LOW LEVEL SWITCH	

### CODICI PER ORDINARE BOBINE DELL'ELETTROVALVOLA – CODES TO ORDER SOLENOID VALVE COILS

14.660.1.R	14.660.2.R	16.660.3.R	14.660.4.R
24 V DC	115 V AC	230 V AC	24 V AC



## MC-EL-3M-4M-5M-6M-7M

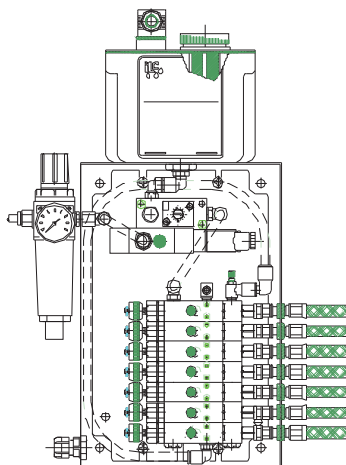

### L'UNITA' E' FORNITA COMPLETA DI:

SERBATOIO 1.2 L O 2.2 L  
LIVELLO ELETTRICO: 1 A 250 V AC 200 V DC 50 W  
3-4-5-6-7 POMPE

**IL TUBO COASSIALE METALLICO VA ORDINATO A PARTE CON CODULO DA 8 MM. VEDI PAGINA 101**

SCATOLA DI PROTEZIONE METALLICA  
ELETTROVALVOLA  
REGOLATORE D'ARIA  
GENERATORE DI FREQUENZA  
RIDUTTORE + MANOMETRO

### THE UNIT IS SUPPLIED COMPLETE OF:

RESERVOIR 1.2 L OR 2.2 L  
LOW LEVEL SWITCH: 1 A 250 V AC 200 V DC 50 W  
3-4-5-6-7 PUMPS

**COAXIAL FEEDING LINES (METALLIC COVERING) MUST BE ORDERED SEPARATELY WITH 8 MM TERMINAL. SEE PAGE 101**

METALLIC BOX  
SOLENOID VALVE  
AIR REGULATOR  
FREQUENCY GENERATOR  
AIR REDUCER + GAUGE

### CODICI DI ORDINAZIONE – CODES FOR ORDER

CODICE CODE	MODELLO TYPE	CODICE CODE	MODELLO TYPE
70.053.1	MC-EL-3M-1.2	70.053.1.SL	MC-EL-3M-1.2-SL
70.053.2	MC-EL-3M-2.2	70.053.2.SL	MC-EL-3M-2.2-SL
70.053.4	MC-EL-4M-1.2	70.053.4.SL	MC-EL-4M-1.2-SL
70.053.5	MC-EL-4M-2.2	70.053.5.SL	MC-EL-4M-2.2-SL
70.053.6	MC-EL-5M-1.2	70.053.6.SL	MC-EL-5M-1.2-SL
70.053.7	MC-EL-5M-2.2	70.053.7.SL	MC-EL-5M-2.2-SL
70.053.8	MC-EL-6M-1.2	70.053.8.SL	MC-EL-6M-1.2-SL
70.053.9	MC-EL-6M-2.2	70.053.9.SL	MC-EL-6M-2.2-SL
70.054.4	MC-EL-7M-1.2	70.054.4.SL	MC-EL-7M-1.2-SL
70.054.5	MC-EL-7M-2.2	70.054.5.SL	MC-EL-7M-2.2-SL
SL: L'UNITA' E' FORNITA SENZA LIVELLO ELETTRICO		SL: THE UNIT WILL BE DELIVERED WITHOUT LOW LEVEL SWITCH	

### CODICI PER ORDINARE BOBINE DELL'ELETTROVALVOLA – CODES TO ORDER SOLENOID VALVE COILS

14.660.1.R	14.660.2.R	14.660.3.R	14.660.4.R
24 V DC	115 V AC	230 V AC	24 V AC



DIMENSIONI D'INGOMBRO

OVERALL DIMENSION

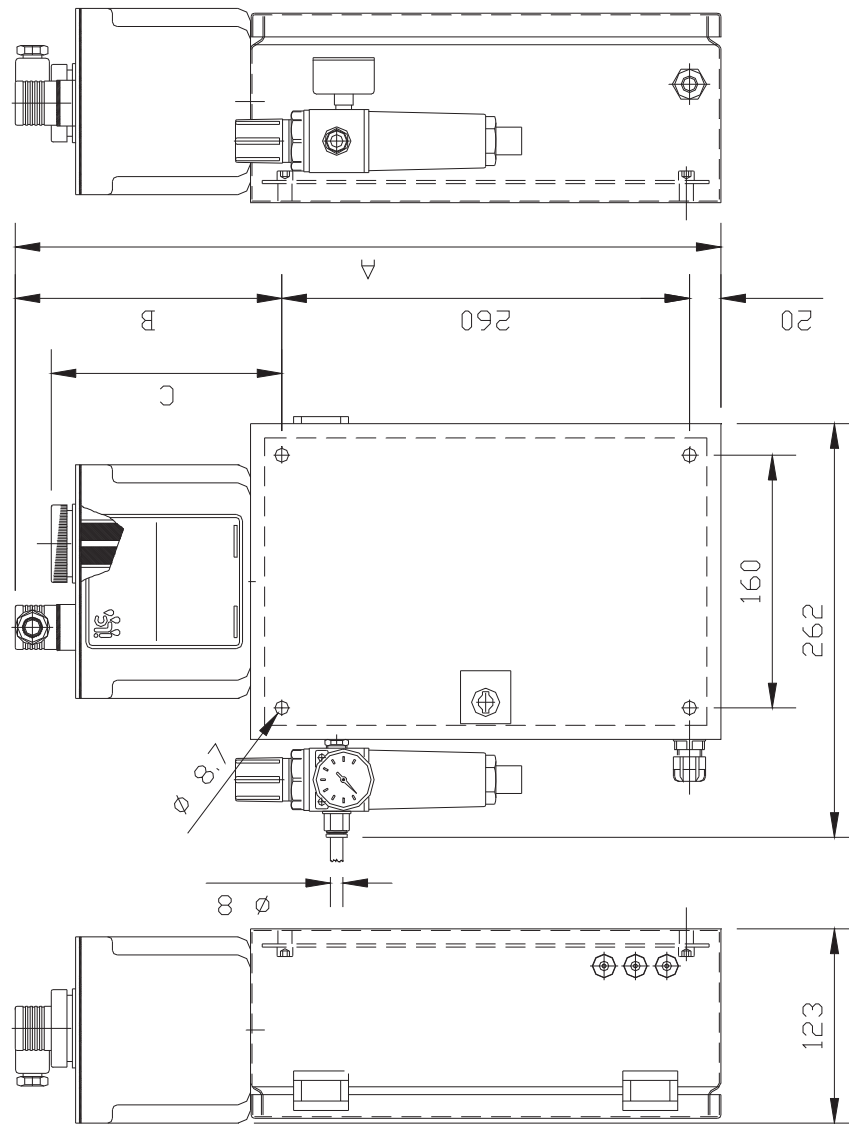

SERBATOIO RESERVOIR	A	B	C
1.2 L	450	170	147
2.2 L	502	222	199



## MC-EL-2P

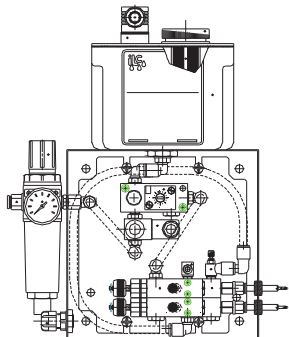

### L'UNITA' E' FORNITA COMPLETA DI:

- SERBATOIO 1.2 L O 2.2 L
- LIVELLO ELETTRICO: 1 A 250 V AC 200 V DC 50 W
- POMPE DA 1 A 2
- 5 M TUBO COASSIALE PER OGNI USCITA (6 MM – 2.5 MM)
- SCATOLA DI PROTEZIONE METALLICA
- L'ELETTRORVALVOLA VA ORDINATA A PARTE  
CODICE 14.660.0
- REGOLATORE D'ARIA
- RIDUTTORE + MANOMETRO
- GENERATORE DI FREQUENZA

### THE UNIT IS SUPPLIED COMPLETE OF:

- RESERVOIR 1.2 L OR 2.2 L
- LOW LEVEL SWITCH: 1 A 250 V AC 200 V DC 50 W
- PUMPS FROM 1 TO 2
- 5 M COAXIAL FEEDING LINES FOR EACH OUTLET (6 MM – 2.5 MM)
- METALLIC BOX
- THE SOLENOID VALVE HAS TO BE ORDERED SEPARATELY  
CODE 14.660.0
- AIR REGULATOR
- AIR REDUCER + GAUGE
- FREQUENCY GENERATOR

### CODICI DI ORDINAZIONE – CODES FOR ORDER

CODICE CODE	MODELLO TYPE	NUMERO DI POMPE PUMPS NUMBER
70.050.3	MC-EL-2P-1.2-1	1
70.050.4	MC-EL-2P-2.2-1	1
70.050.5	MC-EL-2P-1.2-2	2
70.050.6	MC-EL-2P-2.2-2	2
70.050.3.SL	MC-EL-2P-1.2-1-SL	1
70.050.4.SL	MC-EL-2P-2.2-1-SL	1
70.050.5.SL	MC-EL-2P-1.2-2-SL	2
70.050.6.SL	MC-EL-2P-2.2-2-SL	2
SL SIGNIFICA CHE L'UNITA' E' FORNITA SENZA LIVELLO ELETTRICO		SL MEANS THAT THE UNIT WILL BE DELIVERED WITHOUT LOW LEVEL SWITCH

### CODICI PER ORDINARE BOBINE DELL'ELETTRORVALVOLA – CODES TO ORDER SOLENOID VALVE COILS

14.660.1.R	14.660.2.R	14.660.3.R	14.660.4.R
24 V DC	115 V AC	230 V AC	24 V AC





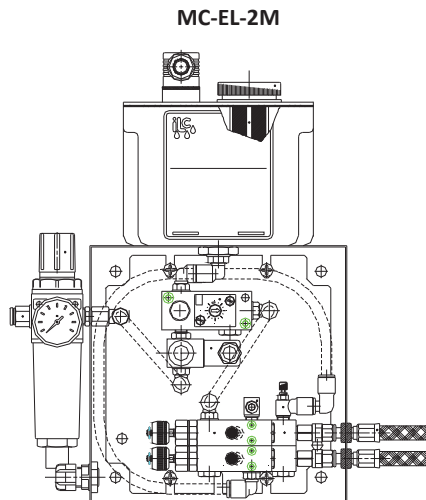

**L'UNITA' E' FORNITA COMPLETA DI:**

- SERBATOIO 1.2 L O 2.2 L
- LIVELLO ELETTRICO: 1 A 250 V AC 200 V DC 50 W
- POMPE DA 1 A 2
- TUBO COASSIALE METALLICO DA ORDINARE A PARTE CON CODULO DA 8 MM. VEDI PAGINA 101**
- SCATOLA DI PROTEZIONE METALLICA
- L'ELETTROVALVOLA VA ORDINATA A PARTE  
CODICE 14.660.0
- REGOLATORE D'ARIA
- RIDUTTORE + MANOMETRO
- GENERATORE DI FREQUENZA

**THE UNIT IS SUPPLIED COMPLETE OF:**

- RESERVOIR 1.2 L OR 2.2 L
- LOW LEVEL SWITCH: 1 A 250 V AC 200 V DC 50 W
- PUMPS FROM 1 TO 2
- COAXIAL FEEDING LINES (METALLIC COVERING). MUST BE ORDERED SEPARATELY WITH 8 MM TERMINAL. SEE PAGE 101**
- METALLIC BOX
- THE SOLENOID VALVE HAS TO BE ORDERED SEPARATELY  
CODE 14.660.0
- AIR REGULATOR
- AIR REDUCER + GAUGE
- FREQUENCY GENERATOR

**CODICI DI ORDINAZIONE – CODES FOR ORDER**

CODICE CODE	MODELLO TYPE	NUMERO DI POMPE PUMPS NUMBER
70.050.1	MC-EL-2M-1.2-1	1
70.051.1	MC-EL-2M-2.2-1	1
70.050.2	MC-EL-2M-1.2-2	2
70.051.2	MC-EL-2M-2.2-2	2
70.050.1.SL	MC-EL-2M-1.2-1-SL	1
70.051.1.SL	MC-EL-2M-2.2-1-SL	1
70.050.2.SL	MC-EL-2M-1.2-2-SL	2
70.051.2.SL	MC-EL-2M-2.2-2-SL	2
SL: L'UNITA' E' FORNITA SENZA LIVELLO ELETTRICO		SL: THE UNIT WILL BE DELIVERED WITHOUT LOW LEVEL SWITCH

**CODICI PER ORDINARE BOBINE DELL'ELETTROVALVOLA – CODES TO ORDER SOLENOID VALVE COILS**

14.660.1.R	14.660.2.R	14.660.3.R	14.660.4.R
24 V DC	115 V AC	230 V AC	24 V AC



DIMENSIONI D'INGOMBRO

OVERALL DIMENSION

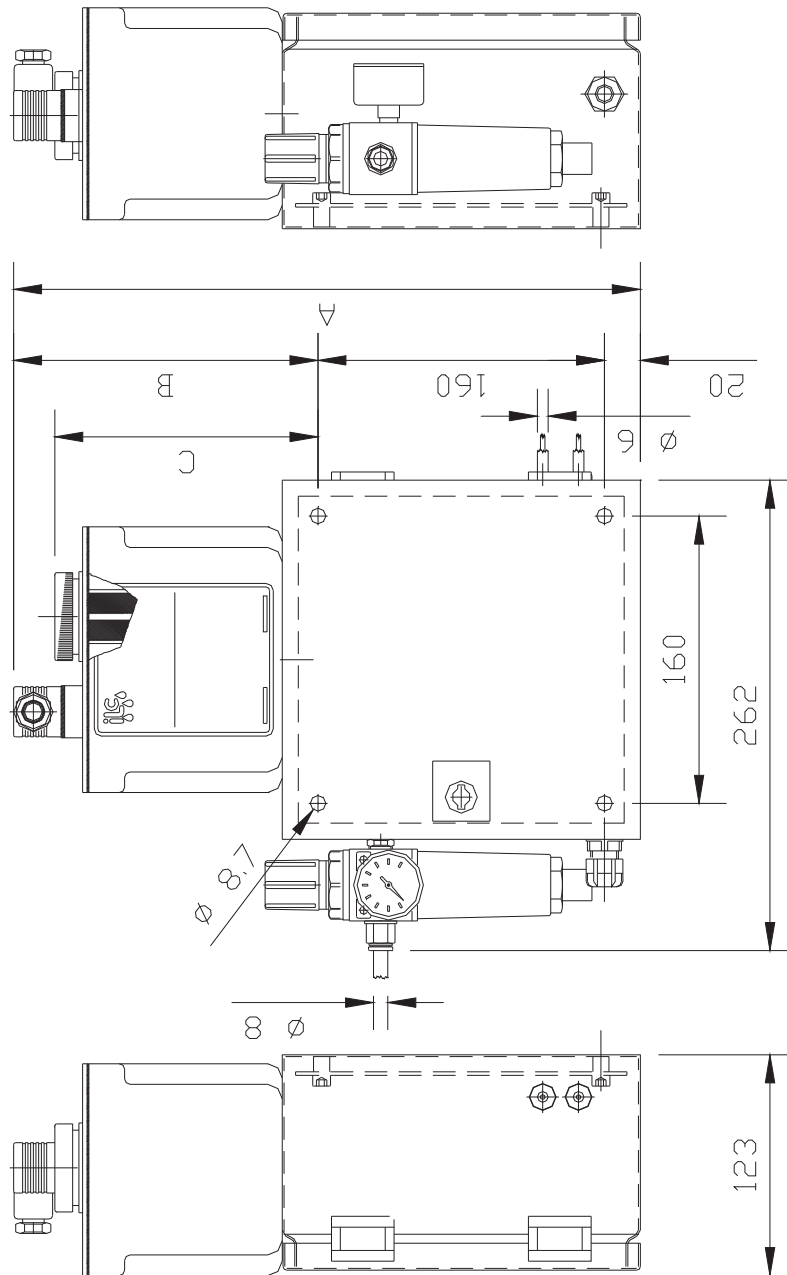

SERBATOIO RESERVOIR	A	B	C
1.2 L	350	170	147
2.2 L	402	222	199



MC-EL-2P-SS

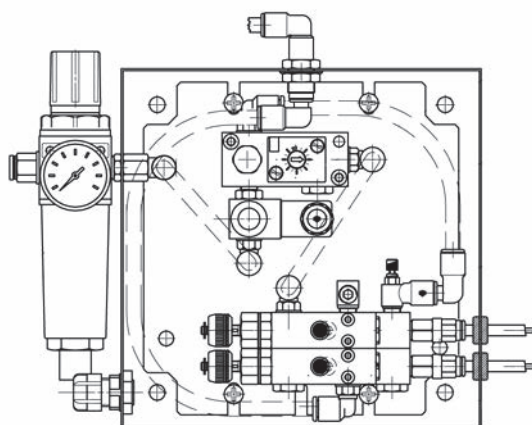

**L'UNITA' E' FORNITA COMPLETA DI:**

- POMPE DA 1 A 2
- TUBO COASSIALE 5 M PER OGNI USCITA (6 MM – 2.5 MM)
- SCATOLA DI PROTEZIONE METALLICA
- L'ELETTOVALVOLA VA ORDINATA A PARTE  
CODICE 14.660.0
- REGOLATORE D'ARIA
- RIDUTTORE + MANOMETRO
- GENERATORE DI FREQUENZA
- IL SERBATOIO DEV'ESSERE ORDINATO A PARTE (VEDI PAG. 90)

**THE UNIT IS SUPPLIED COMPLETE OF:**

- PUMPS FROM 1 TO 2
- 5M COAXIAL FEEDING LINES EVERY OUTLET (6 MM – 2.5 MM)
- METALLIC BOX
- THE SOLENOID VALVE HAS TO BE ORDERED SEPARATELY  
CODE 14.660.0
- AIR REGULATOR
- AIR REDUCER + GAUGE
- FREQUENCY GENERATOR
- RESERVOIR HAS TO BE ORDERED SEPARATELY (SEE PAG. 90)

**CODICI DI ORDINAZIONE – CODES FOR ORDER**

CODICE CODE	MODELLO TYPE	NUMERO DI POMPE PUMPS NUMBER
70.719.1	MC-EL-1P-SS	1
70.718.6	MC-EL-2P-SS	2

**CODICI PER ORDINARE BOBINE DELL'ELETTOVALVOLA – CODES TO ORDER SOLENOID VALVE COILS**

14.660.1.R	14.660.2.R	14.660.3.R	14.660.4.R
24 V DC	115 V AC	230 V AC	24 V AC





## MC-EL-3P-4P-5P-6P-7P

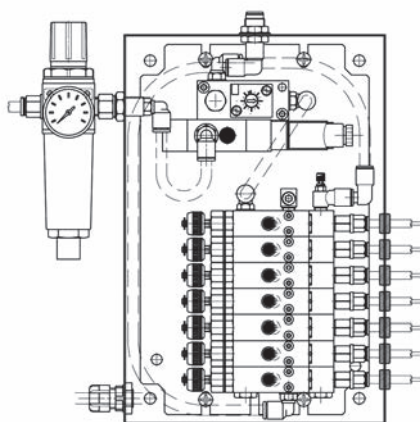

### L'UNITA' E' FORNITA COMPLETA DI:

- POMPE DA 3 A 7
- TUBO COASSIALE 5 M PER OGNI USCITA (6 MM – 2.5 MM)
- SCATOLA DI PROTEZIONE METALLICA
- L'ELETTRIVALVOLA VA ORDINATA A PARTE  
CODICE 14.660.0
- REGOLATORE D'ARIA
- RIDUTTORE + MANOMETRO
- GENERATORE DI FREQUENZA
- IL SERBATOIO DEV'ESSERE ORDINATO A PARTE (VEDI PAG. 90)

### THE UNIT IS SUPPLIED COMPLETE OF:

- PUMPS FROM 3 TO 7
- 5M COAXIAL FEEDING LINES EVERY OUTLET (6 MM – 2.5 MM)
- METALLIC BOX
- THE SOLENOID VALVE HAS TO BE ORDERED SEPARATELY  
CODE 14.660.0
- AIR REGULATOR
- AIR REDUCER + GAUGE
- FREQUENCY GENERATOR
- RESERVOIR HAS TO BE ORDERED SEPARATELY (SEE PAG. 90)

### CODICI DI ORDINAZIONE – CODES FOR ORDER

CODICE CODE	MODELLO TYPE	NUMERO DI POMPE PUMPS NUMBER
70.705.3	MC-EL-3P	3
70.705.4	MC-EL-4P	4
70.705.5	MC-EL-5P	5
70.705.6	MC-EL-6P	6
70.705.7	MC-EL-7P	7

### CODICI PER ORDINARE BOBINE DELL'ELETTRIVALVOLA – CODES TO ORDER SOLENOID VALVE COILS

14.660.1.R	14.660.2.R	14.660.3.R	14.660.4.R
24 V DC	115 V AC	230 V AC	24 V AC



DIMENSIONI D'INGOMBRO

OVERALL DIMENSION

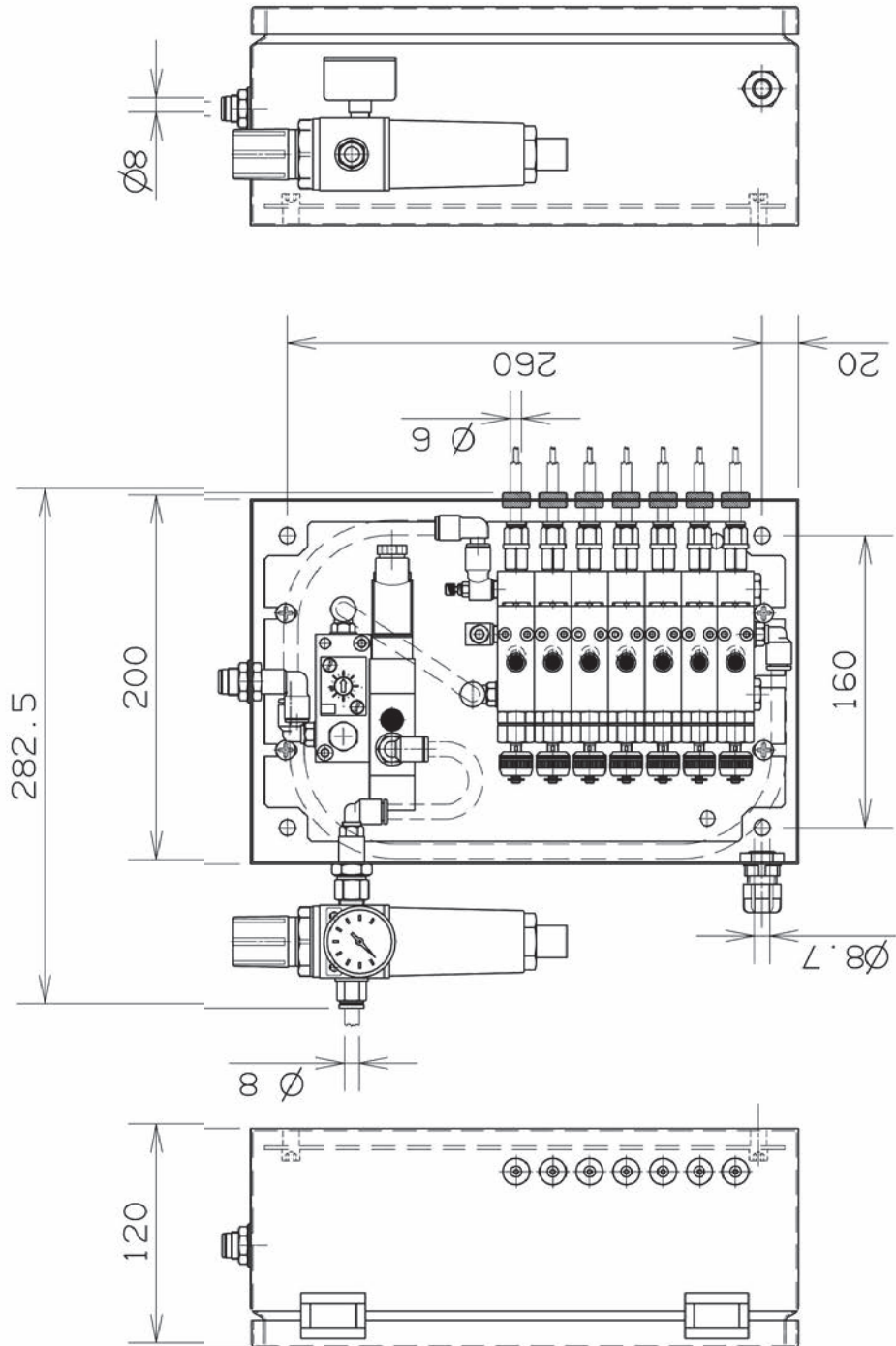



## MC-EL-6L-3P-4P-5P-6P-7P-8P

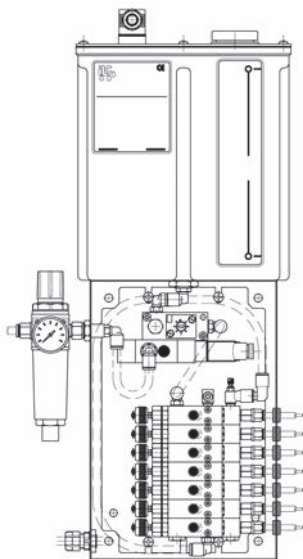

### L'UNITA' E' FORNITA COMPLETA DI:

- LIVELLO ELETTRICO: 1 A 250 V AC 200 V DC 50 W
- POMPE DA 3 A 8
- TUBO COASSIALE 5 M PER OGNI USCITA (6 MM – 2.5 MM)
- SCATOLA DI PROTEZIONE METALLICA
- L'ELETTOVALVOLA VA ORDINATA A PARTE  
CODICE 14.660.0
- REGOLATORE D'ARIA
- RIDUTTORE + MANOMETRO
- GENERATORE DI FREQUENZA

### THE UNIT IS SUPPLIED COMPLETE OF:

- LOW LEVEL SWITCH: 1 A 250 V AC 200 V DC 50 W
- PUMPS FROM 3 TO 8
- 5M COAXIAL FEEDING LINES EVERY OUTLET (6 MM – 2.5 MM)
- METALLIC BOX
- THE SOLENOID VALVE HAS TO BE ORDERED SEPARATELY  
CODE 14.660.0
- AIR REGULATOR
- AIR REDUCER + GAUGE
- FREQUENCY GENERATOR

### CODICI DI ORDINAZIONE – CODES FOR ORDER

CODICE CODE	MODELLO TYPE	NUMERO DI POMPE PUMPS NUMBER	CODICE CODE	MODELLO TYPE	NUMERO DI POMPE PUMPS NUMBER
70.704.3	MC-EL-6L-3P	3	70.704.3.SL	MC-EL-6L-3P-SL	3
70.704.4	MC-EL-6L-4P	4	70.704.4.SL	MC-EL-6L-4P-SL	4
70.704.5	MC-EL-6L-5P	5	70.704.5.SL	MC-EL-6L-5P-SL	5
70.704.6	MC-EL-6L-6P	6	70.704.6.SL	MC-EL-6L-6P-SL	6
70.704.7	MC-EL-6L-7P	7	70.704.7.SL	MC-EL-6L-7P-SL	7
70.730.7	MC-EL-6L-8P	8	70.730.7.SL	MC-EL-6L-8P-SL	8
SL: L'UNITA' E' FORNITA SENZA LIVELLO ELETTRICO			SL: THE UNIT WILL BE DELIVERED WITHOUT LOW LEVEL SWITCH		

### CODICI PER ORDINARE BOBINE DELL'ELETTOVALVOLA – CODES TO ORDER SOLENOID VALVE COILS

14.660.1.R	14.660.2.R	14.660.3.R	14.660.4.R
24 V DC	115 V AC	230 V AC	24 V AC



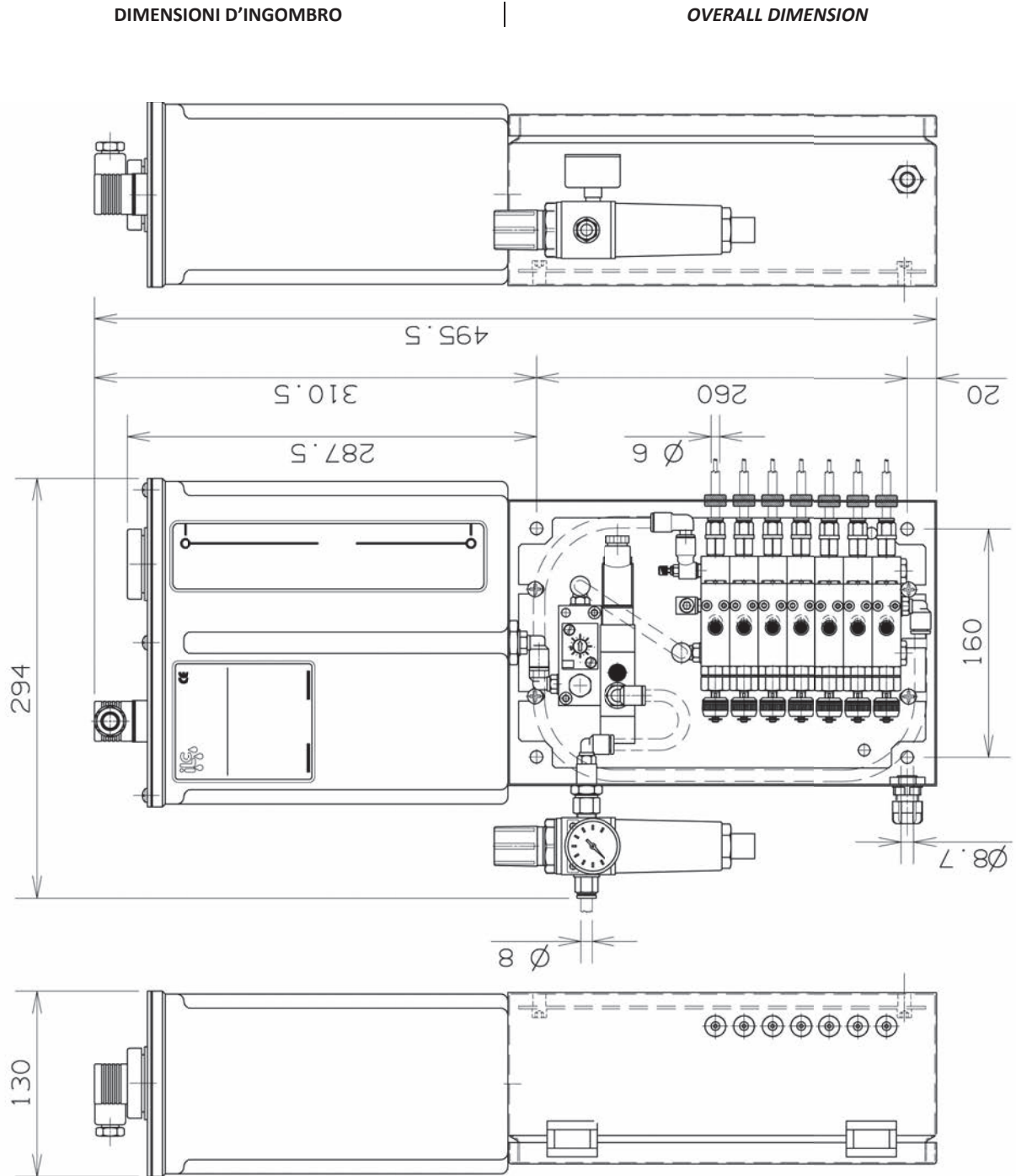

UNITA' LUBETOOL MINI-GF-EL, MINI-GF, MINI-SG-EL, MINI-SG, MINI-035-WFG E MINI-035-FG

LUBETOOL MINI-GF-EL, MINI-GF, MINI-SG-EL, MINI-SG, MINI-035-WFG E MINI-035-FG

SONO FORNITI SENZA SCATOLA DI PROTEZIONE

THEY ARE SUPPLIED WITHOUT BOX

CARATTERISTICHE		FEATURES	
PORTATA	DA 0 MM <sup>3</sup> A 41 MM <sup>3</sup>	DISCHARGE	FROM 0 MM <sup>3</sup> TO 41 MM <sup>3</sup>
POMPE	DA 1 A 2	PUMPS	FROM 1 TO 2
ELETTROVALVOLA	24 V DC – 24 V AC – 115 V AC – 230 V AC	SOLENOID VALVE	24 V DC – 24 V AC – 115 V AC – 230 V AC
CORSE	DA 3 AL SECONDO A 1 AL MINUTO	STROKES	FROM 3 /SECOND TO 1 / MINUTE
SERBATOIO	0.5 L, 1.2 L, 2.2 L O 3.6 L	RESERVOIR	0.5 L, 1.2 L, 2.2 L OR 3.6 L
LUBRIFICANTE	OLIO MAX 800 cSt 40 °C	LUBRICANT	OIL MAX 800 cSt 40 °C
LIVELLO ELETTRICO	1 A 250 V AC – 220 V DC – 50 W	LOW LEVEL SWITCH	1 A 250 V AC – 220 V DC – 50 W
PRESSIONE ARIA	DA 4 BAR A 8 BAR	AIR PRESSURE	FROM 4 BAR TO 8 BAR
CONSUMO ARIA PER PUNTO A 6 BAR	MIN: 60 L/M – MAX 100 L/M	AIR CONSUME AT 6 BAR/POINT	MIN: 60 L/M – MAX 100 L/M



## MINI-GF-EL

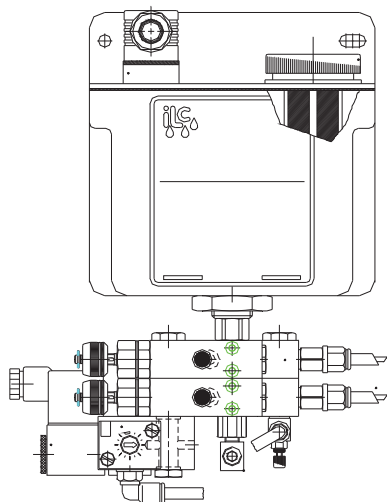

### L'UNITA' E' FORNITA COMPLETA DI:

SERBATOIO 1.2 L, 2.2 L O 3.6 L

LIVELLO ELETTRICO: 1 A 250 V AC 200 V DC 50 W

POMPE DA 1 A 2

5 M TUBO COASSIALE PER OGNI USCITA (6 MM – 2.5 MM)

ELETTROVALVOLA 24 V DC – 24 V AC – 115 V AC O 230 V AC  
LA TENSIONE DEVE ESSERE AGGIUNTA AL CODICE. ESEMPIO  
70.015.0.24VDC

REGOLATORE D'ARIA

GENERATORE DI FREQUENZA

### THE UNIT IS SUPPLIED COMPLETE OF:

RESERVOIR 1.2 L, 2.2 L OR 3.6 L

LOW LEVEL SWITCH: 1 A 250 V AC 200 V DC 50 W

PUMPS FROM 1 TO 2

5 M COAXIAL FEEDING LINES FOR EACH OUTLET (6 MM – 2.5 MM)

SOLENOID VALVE 24 V DC – 24 V AC – 115 V AC OR 230 V AC  
THE VOLTAGE HAS TO BE ADD TO THE CODE. EXAMPLE  
70.015.0.24VDC

AIR REGULATOR

FREQUENCY GENERATOR

### CODICI DI ORDINAZIONE – CODES FOR ORDER

CODICE CODE	MODELLO TYPE	NUMERO DI POMPE PUMPS NUMBER	CODICE CODE	MODELLO TYPE	NUMERO DI POMPE PUMPS NUMBER
70.015.0	MINI-GF-EL-1/1.2 L	1	70.015.0.SL	MINI-GF-EL-1/1.2 L-SL	1
70.020.0	MINI-GF-EL-2/1.2 L	2	70.020.0.SL	MINI-GF-EL-2/1.2 L-SL	2
70.015.1	MINI-GF-EL-1/2.2 L	1	70.015.1.SL	MINI-GF-EL-1/2.2 L-SL	1
70.020.1	MINI-GF-EL-2/2.2 L	2	70.020.1.SL	MINI-GF-EL-2/2.2 L-SL	2
70.015.2	MINI-GF-EL-1/3.6 L	1	70.015.2.SL	MINI-GF-EL-1/3.6 L-SL	1
70.020.2	MINI-GF-EL-2/3.6 L	2	70.020.2.SL	MINI-GF-EL-2/3.6 L-SL	2

SL: L'UNITA' E' FORNITA SENZA LIVELLO ELETTRICO      SL: THE UNIT WILL BE DELIVERED WITHOUT LOW LEVEL SWITCH

### CODICI PER ORDINARE BOBINE DELL'ELETTROVALVOLA – CODES TO ORDER SOLENOID VALVE COILS

14.660.1.R	14.660.2.R	14.660.3.R	14.660.4.R
24 V DC	115 V AC	230 V AC	24 V AC



## MINI-GF

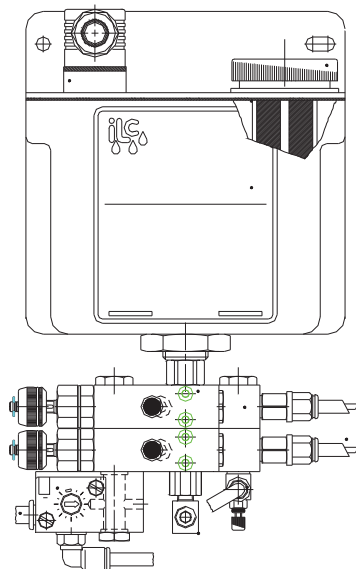

### L'UNITA' E' FORNITA COMPLETA DI:

SERBATOIO 1.2 L, 2.2 L O 3.6 L

LIVELLO ELETTRICO: 1 A 250 V AC 200 V DC 50 W

POMPE DA 1 A 2

5 M TUBO COASSIALE PER OGNI USCITA (6 MM – 2.5 MM)

REGOLATORE D'ARIA

GENERATORE DI FREQUENZA

### THE UNIT IS SUPPLIED COMPLETE OF:

RESERVOIR 1.2 L, 2.2 L OR 3.6 L

LOW LEVEL SWITCH: 1 A 250 V AC 200 V DC 50 W

PUMPS FROM 1 TO 2

5 M COAXIAL FEEDING LINES FOR EACH OUTLET (6 MM – 2.5 MM)

AIR REGULATOR

FREQUENCY GENERATOR

### CODICI DI ORDINAZIONE – CODES FOR ORDER

CODICE CODE	MODELLO TYPE	NUMERO DI POMPE PUMPS NUMBER	CODICE CODE	MODELLO TYPE	NUMERO DI POMPE PUMPS NUMBER
70.004.0	MINI-GF-1/1.2 L	1	70.004.0.SL	MINI-GF-1/1.2 L-SL	1
70.004.1	MINI-GF-2/1.2 L	2	70.004.1.SL	MINI-GF-2/1.2 L-SL	2
70.004.2	MINI-GF-1/2.2 L	1	70.004.2.SL	MINI-GF-1/2.2 L-SL	1
70.004.3	MINI-GF-2/2.2 L	2	70.004.3.SL	MINI-GF-2/2.2 L-SL	2
70.004.4	MINI-GF-1/3.6 L	1	70.004.4.SL	MINI-GF-1/3.6 L-SL	1
70.004.5	MINI-GF-2/3.6 L	2	70.004.5.SL	MINI-GF-2/3.6 L-SL	2
SL SIGNIFICA CHE L'UNITA' E' FORNITA SENZA LIVELLO ELETTRICO			SL MEANS THAT THE UNIT WILL BE DELIVERED WITHOUT LOW LEVEL SWITCH		



**DIMENSIONI D'INGOMBRO MINI-GF-EL**

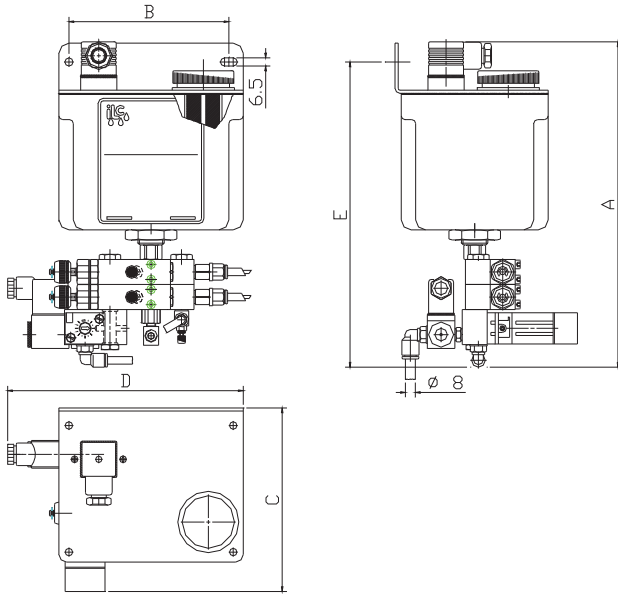

**OVERALL DIMENSION MINI-GF-EL**

POMPE PUMPS	SERBATOIO RESERVOIR	A	B	C	D	E
1	1.2 L	240	129	146	190	224
2	1.2 L	260	129	146	190	244
1	2.2 L	292	129	146	190	276
2	2.2 L	312	129	146	190	296
1	3.6 L	287	173	153	230	271
2	3.6 L	307	173	153	230	291

**DIMENSIONI D'INGOMBRO MINI-GF**

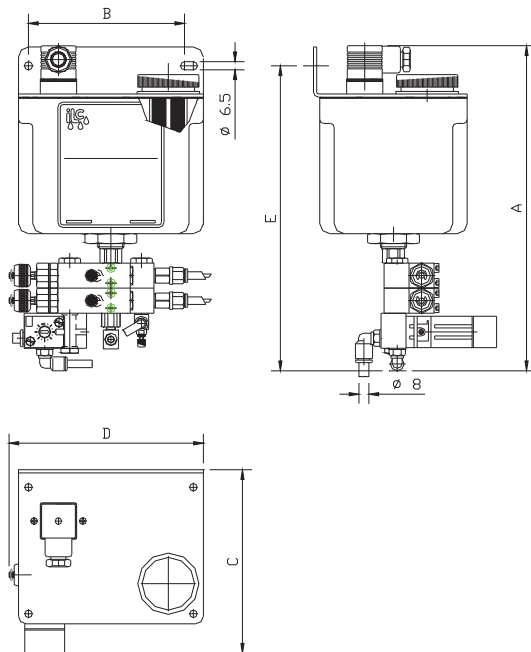

**OVERALL DIMENSION MINI-GF**

POMPE PUMPS	SERBATOIO RESERVOIR	A	B	C	D	E
1	1.2 L	260	129	147	155	244
2	1.2 L	280	129	147	155	264
1	2.2 L	312	129	147	155	296
2	2.2 L	332	129	147	155	316
1	3.6 L	307	173	153	230	291
2	3.6 L	327	173	153	230	311





## MINI-SG-EL

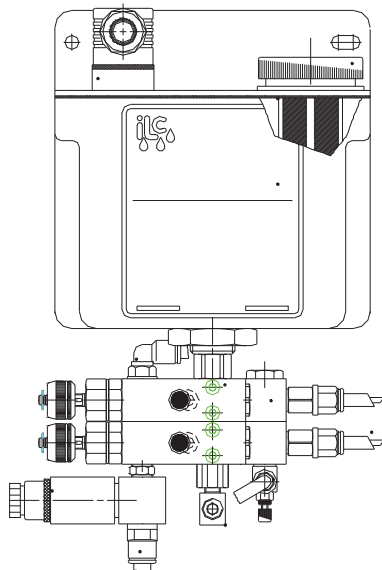

### L'UNITA' E' FORNITA COMPLETA DI:

- SERBATOIO 1.2 L, 2.2 L O 3.6 L
- LIVELLO ELETTRICO: 1 A 250 V AC 200 V DC 50 W
- POMPE DA 1 A 2
- 5 M TUBO COASSIALE PER OGNI USCITA (6 MM – 2.5 MM)

ELETTROVALVOLA 24 V DC – 24 V AC – 115 V AC O 230 V AC  
LA TENSIONE DEVE ESSERE AGGIUNTA AL CODICE. ESEMPIO  
70.017.0.24VDC

REGOLATORE D'ARIA

### THE UNIT IS SUPPLIED COMPLETE OF:

- RESERVOIR 1.2 L, 2.2 L OR 3.6 L
- LOW LEVEL SWITCH: 1 A 250 V AC 200 V DC 50 W
- PUMPS FROM 1 TO 2
- 5 M COAXIAL FEEDING LINES FOR EACH OUTLET (6 MM – 2.5 MM)

SOLENOID VALVE 24 V DC – 24 V AC – 115 V AC OR 230 V AC  
THE VOLTAGE HAS TO BE ADD TO THE CODE. EXAMPLE  
70.017.0.24VDC

AIR REGULATOR

### CODICI DI ORDINAZIONE – CODES FOR ORDER

CODICE CODE	MODELLO TYPE	NUMERO DI POMPE PUMPS NUMBER	CODICE CODE	MODELLO TYPE	NUMERO DI POMPE PUMPS NUMBER
70.017.0	MINI-SG-EL-1/1.2 L	1	70.017.0.SL	MINI-SG-EL-1/1.2 L-SL	1
70.017.1	MINI-SG-EL-2/1.2 L	2	70.017.1.SL	MINI-SG-EL-2/1.2 L-SL	2
70.017.2	MINI-SG-EL-1/2.2 L	1	70.017.2.SL	MINI-SG-EL-1/2.2 L-SL	1
70.017.3	MINI-SG-EL-2/2.2 L	2	70.017.3.SL	MINI-SG-EL-2/2.2 L-SL	2
70.017.4	MINI-SG-EL-1/3.6 L	1	70.017.4.SL	MINI-SG-EL-1/3.6 L-SL	1
70.017.5	MINI-SG-EL-2/3.6 L	2	70.017.5.SL	MINI-SG-EL-2/3.6 L-SL	2
SL: L'UNITA' E' FORNITA SENZA LIVELLO ELETTRICO			SL: THE UNIT WILL BE DELIVERED WITHOUT LOW LEVEL SWITCH		

### CODICI PER ORDINARE BOBINE DELL'ELETTROVALVOLA – CODES TO ORDER SOLENOID VALVE COILS

14.660.1.R	14.660.2.R	14.660.3.R	14.660.4.R
24 V DC	115 V AC	230 V AC	24 V AC



MINI-SG

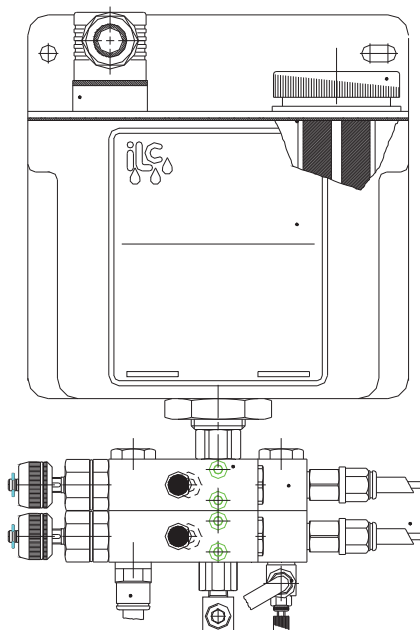

**L'UNITA' E' FORNITA COMPLETA DI:**

- SERBATOIO 1.2 L, 2.2 L O 3.6 L
- LIVELLO ELETTRICO: 1 A 250 V AC 200 V DC 50 W
- POMPE DA 1 A 2
- 5 M TUBO COASSIALE PER OGNI USCITA (6 MM – 2.5 MM)
- REGOLATORE D'ARIA

**THE UNIT IS SUPPLIED COMPLETE OF:**

- RESERVOIR 1.2 L, 2.2 L OR 3.6 L
- LOW LEVEL SWITCH: 1 A 250 V AC 200 V DC 50 W
- PUMPS FROM 1 TO 2
- 5 M COAXIAL FEEDING LINES FOR EACH OUTLET (6 MM – 2.5 MM)
- AIR REGULATOR

CODICI DI ORDINAZIONE – CODES FOR ORDER

CODICE CODE	MODELLO TYPE	NUMERO DI POMPE PUMPS NUMBER	CODICE CODE	MODELLO TYPE	NUMERO DI POMPE PUMPS NUMBER
70.005.0	MINI-SG-1/1.2 L	1	70.005.0.SL	MINI-SG-1/1.2 L-SL	1
70.005.1	MINI-SG-2/1.2 L	2	70.005.1.SL	MINI-SG-2/1.2 L-SL	2
70.005.2	MINI-SG-1/2.2 L	1	70.005.2.SL	MINI-SG-1/2.2 L-SL	1
70.005.3	MINI-SG-2/2.2 L	2	70.005.3.SL	MINI-SG-2/2.2 L-SL	2
70.005.4	MINI-SG-1/3.6 L	1	70.005.4.SL	MINI-SG-1/3.6 L-SL	1
70.005.5	MINI-SG-2/3.6 L	2	70.005.5.SL	MINI-SG-2/3.6 L-SL	2
SL SIGNIFICA CHE L'UNITA' E' FORNITA SENZA LIVELLO ELETTRICO			SL MEANS THAT THE UNIT WILL BE DELIVERED WITHOUT LOW LEVEL SWITCH		



**DIMENSIONI D'INGOMBRO MINI-SG-EL**

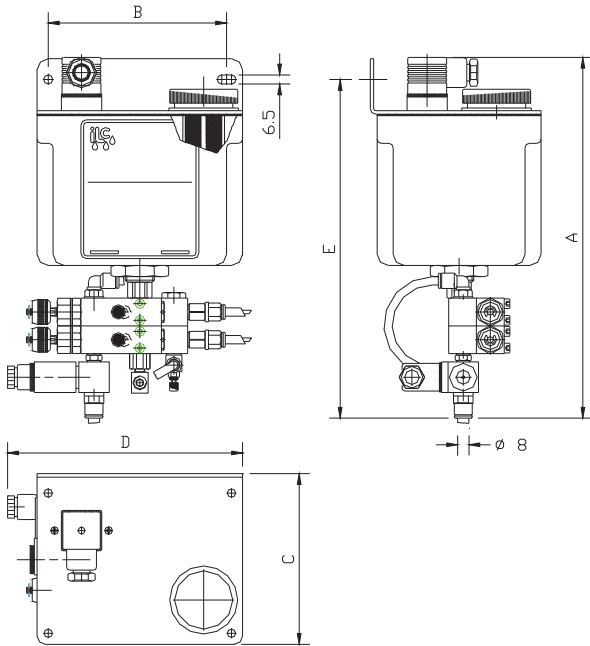

**OVERALL DIMENSION MINI-SG-EL**

POMPE PUMPS	SERBATOIO RESERVOIR	A	B	C	D	E
1	1.2 L	240	129	123	170	224
2	1.2 L	260	129	123	170	244
1	2.2 L	292	129	123	170	276
2	2.2 L	312	129	123	170	296
1	3.6 L	287	173	135	230	271
2	3.6 L	307	173	135	230	291

**DIMENSIONI D'INGOMBRO MINI-SG**

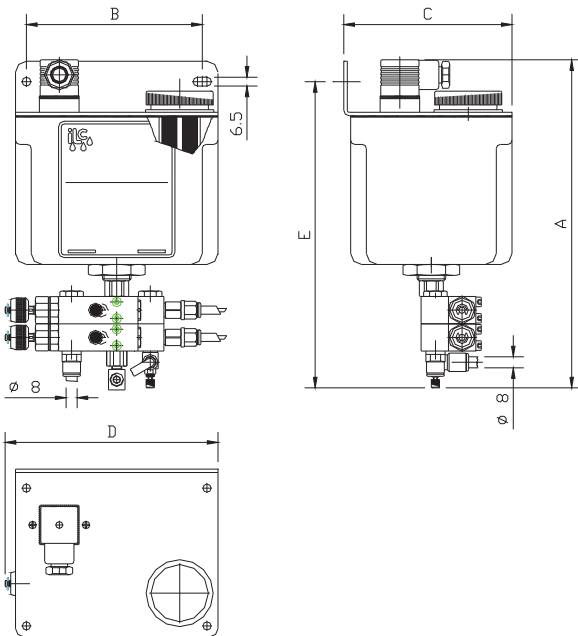

**OVERALL DIMENSION MINI-SG**

POMPE PUMPS	SERBATOIO RESERVOIR	A	B	C	D	E
1	1.2 L	220	129	123	155	204
2	1.2 L	240	129	123	155	224
1	2.2 L	272	129	123	155	256
2	2.2 L	292	129	123	155	276
1	3.6 L	215	173	135	230	251
2	3.6 L	235	173	135	230	271



## MINI-GF-EL-SS

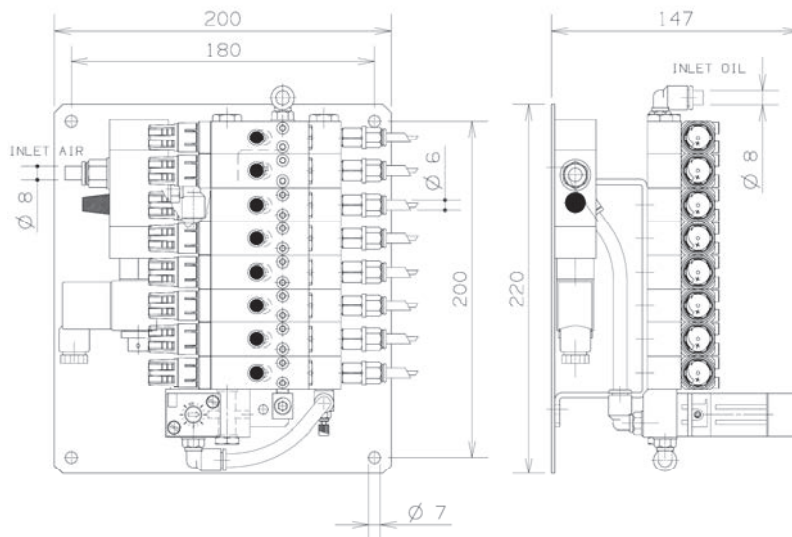

### L'UNITA' E' FORNITA COMPLETA DI:

- POMPE DA 1 A 6
- TUBO COASSIALE 5 M PER OGNI USCITA (6 MM – 2.5 MM)
- L'ELETTRIVALVOLA VA ORDINATA A PARTE  
CODICE 14.660.0
- REGOLATORE D'ARIA
- RIDUTTORE + MANOMETRO
- GENERATORE DI FREQUENZA
- IL SERBATOIO DEV'ESSERE ORDINATO A PARTE (VEDI PAG. 90)

### THE UNIT IS SUPPLIED COMPLETE OF:

- PUMPS FROM 1 TO 2
- 5M COAXIAL FEEDING LINES EVERY OUTLET (6 MM – 2.5 MM)
- THE SOLENOID VALVE HAS TO BE ORDERED SEPARATELY  
CODE 14.660.0
- AIR REGULATOR
- AIR REDUCER + GAUGE
- FREQUENCY GENERATOR
- RESERVOIR HAS TO BE ORDERED SEPARATELY (SEE PAG. 90)

### CODICI DI ORDINAZIONE – CODES FOR ORDER

CODICE CODE	MODELLO TYPE	NUMERO DI POMPE PUMPS NUMBER
70.716.1	MINI-GF-EL-1P-SS	1
70.716.2	MINI-GF-EL-2P-SS	2
70.716.3	MINI-GF-EL-3P-SS	3
70.716.4	MINI-GF-EL-4P-SS	4
70.716.5	MINI-GF-EL-5P-SS	5
70.716.6	MINI-GF-EL-6P-SS	6
70.737.2	MINI-GF-EL-7P-SS	7
70.737.3	MINI-GF-EL-8P-SS	8

### CODICI PER ORDINARE BOBINE DELL'ELETTRIVALVOLA – CODES TO ORDER SOLENOID VALVE COILS

14.660.1.R	14.660.2.R	14.660.3.R	14.660.4.R
24 V DC	115 V AC	230 V AC	24 V AC



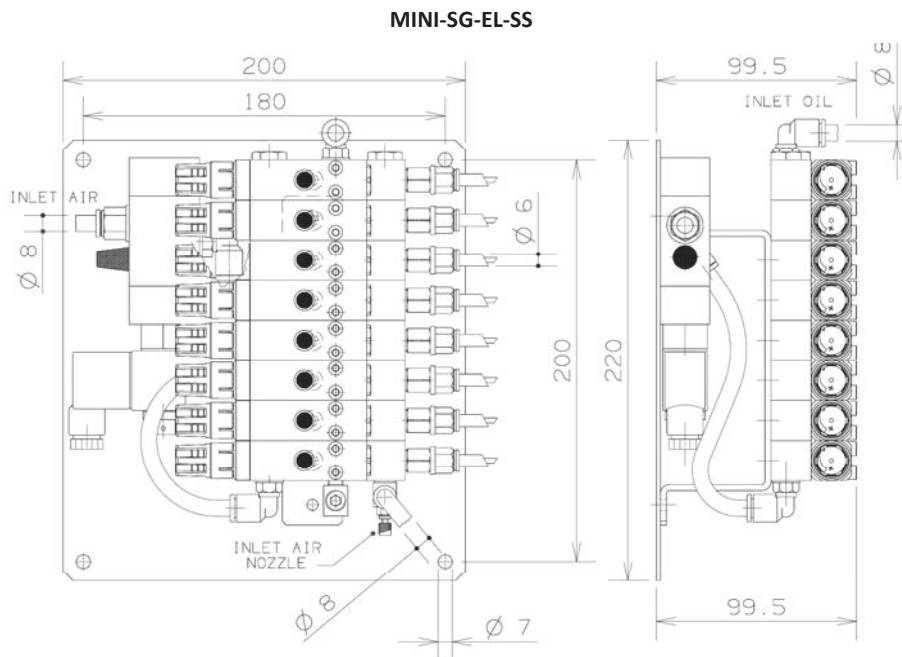

**L'UNITA' E' FORNITA COMPLETA DI:**

- POMPE DA 1 A 6
- TUBO COASSIALE 5 M PER OGNI USCITA (6 MM – 2.5 MM)
- L'ELETTRORVALVOLA VA ORDINATA A PARTE  
CODICE 14.660.0
- REGOLATORE D'ARIA
- RIDUTTORE + MANOMETRO
- IL SERBATOIO DEV'ESSERE ORDINATO A PARTE (VEDI PAG. 90)

**THE UNIT IS SUPPLIED COMPLETE OF:**

- PUMPS FROM 1 TO 2
- 5M COAXIAL FEEDING LINES EVERY OUTLET (6 MM – 2.5 MM)
- THE SOLENOID VALVE HAS TO BE ORDERED SEPARATELY  
CODE 14.660.0
- AIR REGULATOR
- AIR REDUCER + GAUGE
- RESERVOIR HAS TO BE ORDERED SEPARATELY (SEE PAG. 90)

**CODICI DI ORDINAZIONE – CODES FOR ORDER**

CODICE CODE	MODELLO TYPE	NUMERO DI POMPE PUMPS NUMBER
70.716.1.SG	MINI-SG-EL-1P-SS	1
70.716.2.SG	MINI-SG-EL-2P-SS	2
70.716.3.SG	MINI-SG-EL-3P-SS	3
70.716.4.SG	MINI-SG-EL-4P-SS	4
70.716.5.SG	MINI-SG-EL-5P-SS	5
70.716.6.SG	MINI-SG-EL-6P-SS	6
70.737.2.SG	MINI-SG-EL-7P-SS	7
70.737.3.SG	MINI-SG-EL-8P-SS	8

**CODICI PER ORDINARE BOBINE DELL'ELETTRORVALVOLA – CODES TO ORDER SOLENOID VALVE COILS**

14.660.1.R	14.660.2.R	14.660.3.R	14.660.4.R
24 V DC	115 V AC	230 V AC	24 V AC



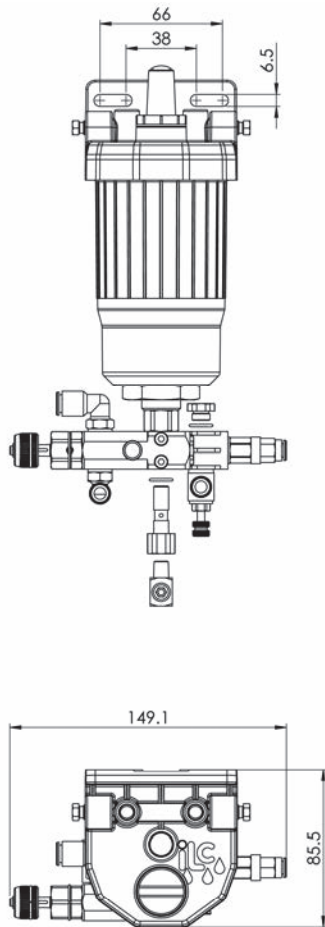

MINI-035-WFG

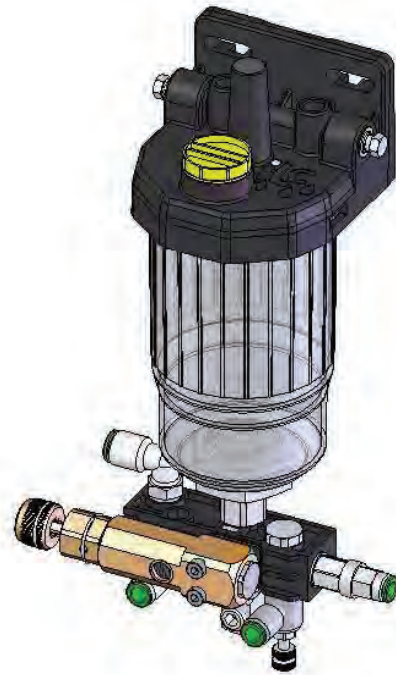
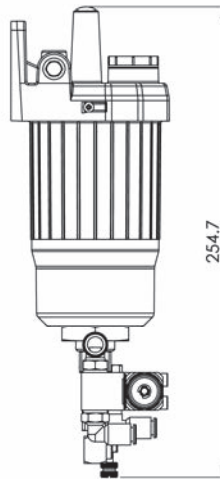

CODICE / CODE  
70.055.0

SERBATOIO / RESERVOIR  
0.5 L

**L'UNITA' E' FORNITA COMPLETA DI:**

- SERBATOIO 0.5 L
- 1 POMPA
- 5 M TUBO COASSIALE PER OGNI USCITA (6 MM – 2.5 MM)
- REGOLATORE D'ARIA

**THE UNIT IS SUPPLIED COMPLETE OF:**

- RESERVOIR 0.5 L
- 1 PUMP
- 5 M COAXIAL FEEDING LINES FOR EACH OUTLET (6 MM – 2.5 MM)
- AIR REGULATOR





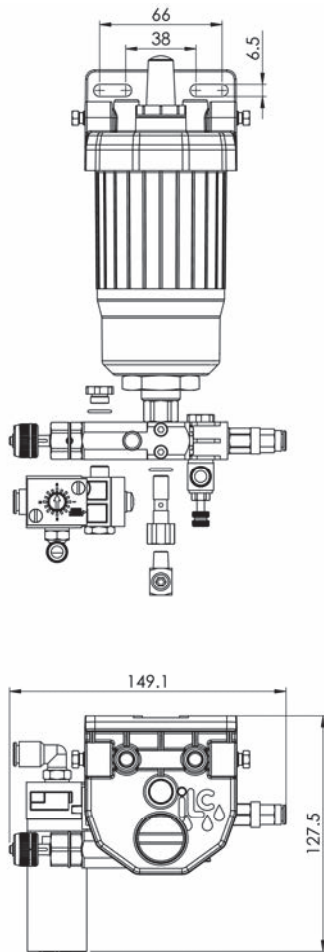

MINI-035-FG

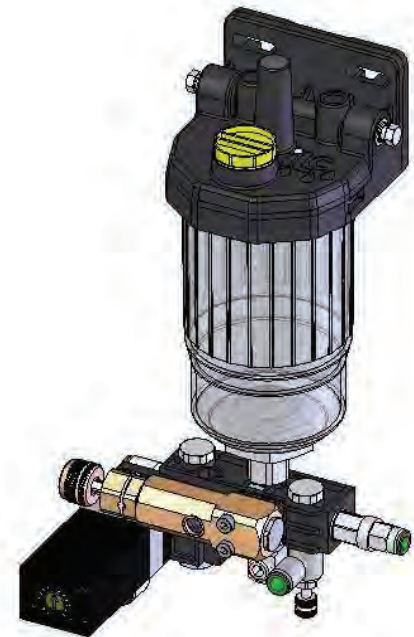
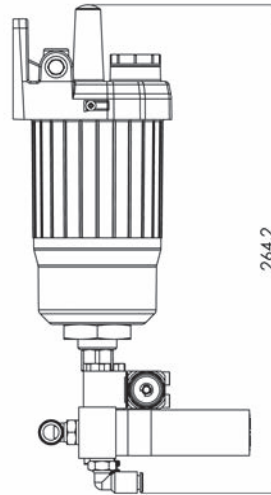

CODICE / CODE  
70.055.1

SERBATOIO / RESERVOIR  
0.5 L

**L'UNITA' E' FORNITA COMPLETA DI:**

- SERBATOIO 0.5 L
- 1 POMPA
- 5 M TUBO COASSIALE PER OGNI USCITA (6 MM – 2.5 MM)
- REGOLATORE D'ARIA
- GENERATORE DI FREQUENZA

**THE UNIT IS SUPPLIED COMPLETE OF:**

- RESERVOIR 0.5 L
- 1 PUMP
- 5 M COAXIAL FEEDING LINES FOR EACH OUTLET (6 MM – 2.5 MM)
- AIR REGULATOR
- FREQUENCY GENERATOR



## UNITA' LUBETOOL MIX

SONO STATE PROGETTATE PER LUBRIFICARE CON DUE LIQUIDI

## LUBETOOL MIX

THEY WERE DESIGNED TO LUBRICATE WITH TWO LIQUIDS

CARATTERISTICHE		FEATURES	
PORTATA	DA 0 MM <sup>3</sup> A 41 MM <sup>3</sup>	DISCHARGE	FROM 0 MM <sup>3</sup> TO 41 MM <sup>3</sup>
POMPE	DA 3 A 4	PUMPS	FROM 3 TO 4
ELETTRIVALVOLA	24 V DC – 24 V AC – 115 V AC – 230 V AC	SOLENOID VALVE	24 V DC – 24 V AC – 115 V AC – 230 V AC
CORSE	DA 3 AL SECONDO A 1 AL MINUTO	STROKES	FROM 3 /SECOND TO 1 / MINUTE
SERBATOIO	1.2 L, 2.2 L	RESERVOIR	1.2 L, 2.2 L
LUBRIFICANTE	OLIO MAX 800 cSt 40 °C	LUBRICANT	OIL MAX 800 cSt 40 °C
LIVELLO ELETTRICO	1 A 250 V AC – 220 V DC – 50 W	LOW LEVEL SWITCH	1 A 250 V AC – 220 V DC – 50 W
PRESSIONE ARIA	DA 4 BAR A 8 BAR	AIR PRESSURE	FROM 4 BAR TO 8 BAR
CONSUMO ARIA PER PUNTO A 6 BAR	MIN: 60 L/M – MAX 100 L/M	AIR CONSUME AT 6 BAR/POINT	MIN: 60 L/M – MAX 100 L/M



## MIX CON CONTENITORE IN PLASTICA

QUESTE UNITA', PROGETTATE PER L'APPLICAZIONE IN CASI DI ELEVATA PRODUZIONE, TROVANO LA LORO COLLOCAZIONE IDEALE NELLE LINEE DI TAGLIO AUTOMATICHE A DISCO, SEGATRICI A DISCO/NASTRO PER TAGLI DI GRANDE DIAMETRO O DOVUNQUE E' RICHiesto UN PARTICOLARE ABBINAMENTO FRA LA MICRO LUBRIFICAZIONE TRADIZIONALE ED IL RAFFREDDAMENTO.

UNA LINEA DI MANDATA INVIA OLIO E LO SPRUZZA FRONTALMENTE NEI DENTI DELLA LAMA, LA SECONDA LINEA INVIA EMULSIONE E LO SPRUZZA NEI FIANCHI.

SI OTTENGONO NOTEVOLI VANTAGGI SIA NELLA QUALITA' DEL TAGLIO, SIA NELLA DURATA DELLA LAMA.

L'UNITA' PREVEDE UN SOLO COMANDO IN QUANTO LE DUE LINEE FUNZIONANO CONTEMPORANEAMENTE, MENTRE I DUE SERBATOI SONO SEPARATI.

L'UNITA' STANDARD VIENE FORNITA COMPLETA DI TUBI COASSIALI DA 5 M

A RICHIESTA E' POSSIBILE ESEGUIRE ESECUZIONI SPECIALI.

## MIX WITH PLASTIC CONTAINER

THIS SYSTEM IS USED IN CASE OF HIGH PRODUCTION, TO CUT HIGH DIAMETERS AND WHERE IS NECESSARY TO USE THE MICRO LUBRICATION TOGETHER WITH THE TRADITIONAL LUBRICATION.

A LINE SEND OIL TO BE SPRAYED FRONTALLY ON THE TEETH AND A SECOND LINE SEND EMULSION TO BE SPRAYED ON THE SIDES.

AS A RESULT THERE IS AN HIGH CUT QUALITY AND A LONG LIFE TOOL.

THE UNIT NEED A UNIQUE DRIVE BECAUSE THE TWO LINES ARE WORKING IN THE SAME TIME AND THE TWO RESERVOIRS ARE SEPARATE.

THE STANDARD UNIT IS COMPLETE WITH 5 M COAXIAL HOSES.

ON REQUEST IT IS POSSIBLE TO HAVE DIFFERENT SOLUTION.

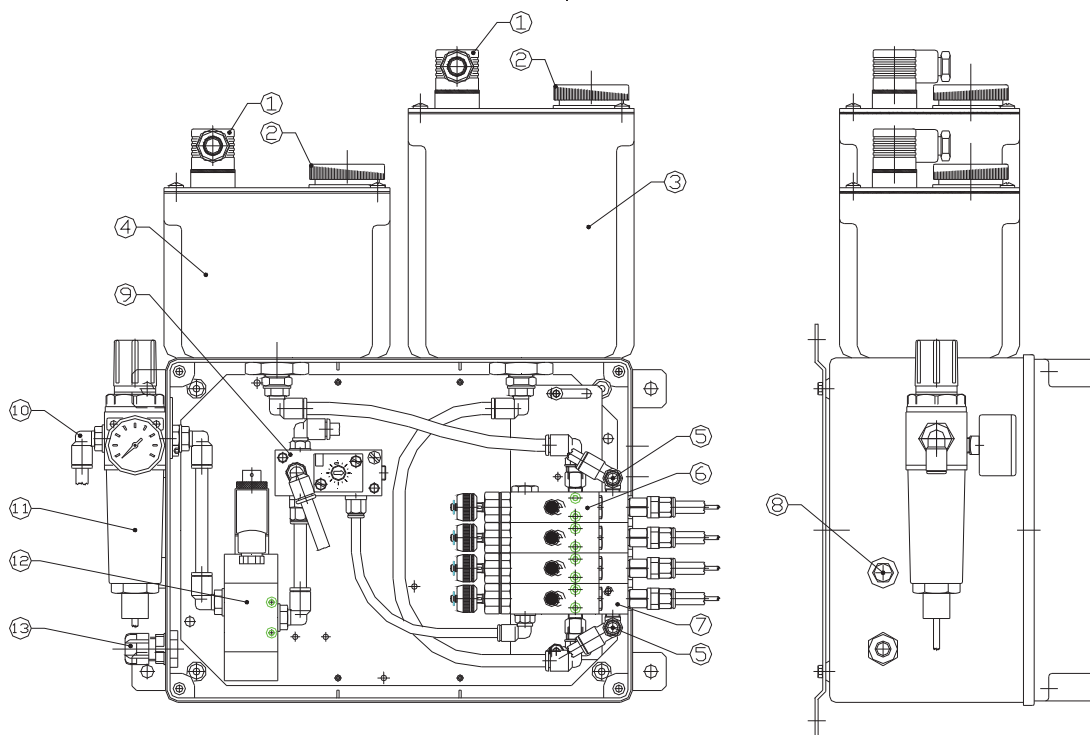

CODICI DI ORDINAZIONE – CODES FOR ORDER

CODICE CODE	MODELLO	TYPE
70.060.3	MIX 1 (OLIO) + 2 (EMULSIONE)	MIX 1 (OIL) + 2 (EMULSION)
70.060.4	MIX 2 (OLIO) + 2 (EMULSIONE)	MIX 2 (OIL) + 2 (EMULSION)



L'UNITA' E' FORNITA COMPLETA DI:		THE UNIT IS SUPPLIED COMPLETE OF:
1	LIVELLI ELETTRICI	LOW LEVEL SWITCHES
2	TAPPI DI RIEMPIMENTO CON FILTRO	FILLER CUPS + STRAINER
3	SERBATOIO 2.2 L PER EMULSIONE	RESERVOIR 2.2 L FOR EMULSION
4	SERBATOIO 1.2 L PER OLIO	RESERVOIR 1.2 L FOR OIL
5	REGOLATORI ARIA	AIR REGULATORS
6	POMPE 3 O 4	3 OR 4 PUMPS
7	BASI POMPE 3 O 4	3 OR 4 PUMP BASES
8	FILTRO SCARICO ARIA	STRAINER EXHAUST AIR
9	GENERATORE DI FREQUENZA	FREQUENCY GENERATOR
10	RACCORDO INGRESSO ARIA PUSH-IN 8 MM	AIR INLET FITTINGS PUSH-IN 8 MM
11	RIDUTTORE CON MANOMETRO	PRESSURE REDUCER WITH GAUGE
12	ELETTROVALVOLA 24 V DC – 24 V AC – 115 V AC O 230 V AC  LA TENSIONE DEVE ESSERE AGGIUNTA AL CODICE. ESEMPIO 70.060.3.24VDC	SOLENOID VALVE 24 V DC – 24 V AC – 115 V AC OR 230 V AC  THE VOLTAGE HAS TO BE ADD TO THE CODE. EXAMPLE 70.060.3.24VDC
13	PRESSACAVO	CABLE GLAND
5 M TUBO COASSIALE PER OGNI USCITA (6 MM – 2.5 MM)		5 M COAXIAL HOSE FOR EACH OUTLET (6 MM – 2.5 MM)

DIMENSIONI D'INGOMBRO

OVERALL DIMENSION

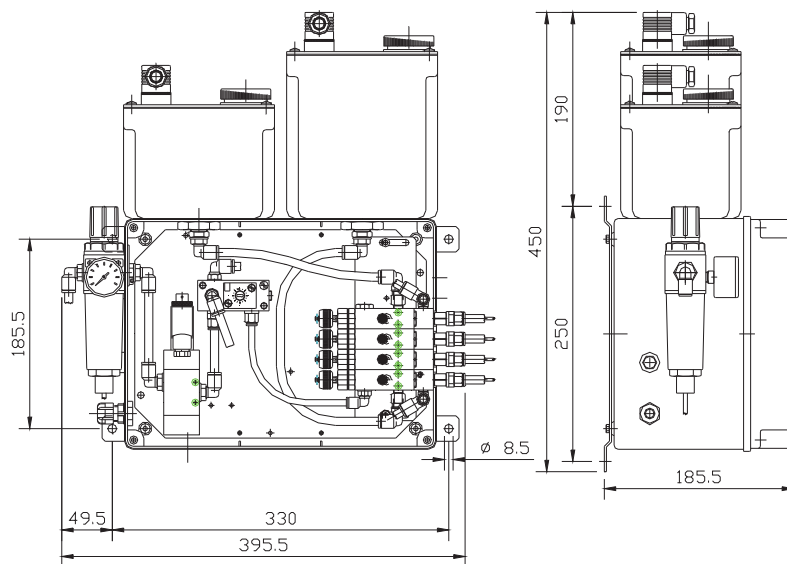

CODICI PER ORDINARE BOBINE DELL'ELETTROVALVOLA – CODES TO ORDER SOLENOID VALVE COILS

14.660.1.R	14.660.2.R	14.660.3.R	14.660.4.R
24 V DC	115 V AC	230 V AC	24 V AC



## MIX CON CONTENITORE METALLICO

QUESTE UNITA', PROGETTATE PER L'APPLICAZIONE IN CASI DI ELEVATA PRODUZIONE, TROVANO LA LORO COLLOCAZIONE IDEALE NELLE LINEE DI TAGLIO AUTOMATICHE A DISCO, SEGATRICI A DISCO/NASTRO PER TAGLI DI GRANDE DIAMETRO O DOVUNQUE E' RICHiesto UN PARTICOLARE ABBINAMENTO FRA LA MICRO LUBRIFICAZIONE TRADIZIONALE ED IL RAFFREDDAMENTO.

UNA LINEA DI MANDATA INVIA OLIO E LO SPRUZZA FRONTALMENTE NEI DENTI DELLA LAMA, LA SECONDA LINEA INVIA EMULSIONE E LO SPRUZZA NEI FIANCHI.

SI OTTENGONO NOTEVOLI VANTAGGI SIA NELLA QUALITA' DEL TAGLIO, SIA NELLA DURATA DELLA LAMA.

L'UNITA' PREVEDE UN SOLO COMANDO IN QUANTO LE DUE LINEE FUNZIONANO CONTEMPORANEAMENTE, MENTRE I DUE SERBATOI SONO SEPARATI.

L'UNITA' STANDARD VIENE FORNITA COMPLETA DI TUBI COASSIALI DA 5 M

A RICHIESTA E' POSSIBILE ESEGUIRE ESECUZIONI SPECIALI.

## MIX WITH METALLIC BOX

THIS SYSTEM IS USED IN CASE OF HIGH PRODUCTION, TO CUT HIGH DIAMETERS AND WHERE IS NECESSARY TO USE THE MICRO LUBRICATION TOGETHER WITH THE TRADITIONAL LUBRICATION.

A LINE SEND OIL TO BE SPRAYED FRONTALLY ON THE TEETH AND A SECOND LINE SEND EMULSION TO BE SPRAYED ON THE SIDES.

AS A RESULT THERE IS AN HIGH CUT QUALITY AND A LONG LIFE TOOL.

THE UNIT NEED A UNIQUE DRIVE BECAUSE THE TWO LINES ARE WORKING IN THE SAME TIME AND THE TWO RESERVOIRS ARE SEPARATE.

THE STANDARD UNIT IS COMPLETE WITH 5 M COAXIAL HOSES.

ON REQUEST IT IS POSSIBLE TO HAVE DIFFERENT SOLUTION.

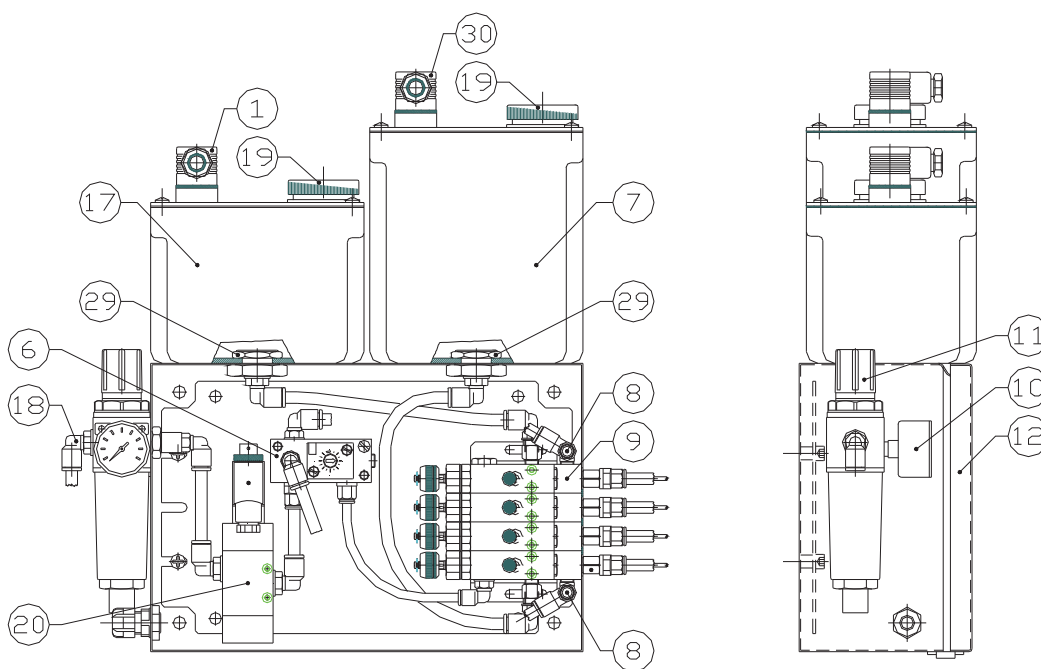

CODICI DI ORDINAZIONE – CODES FOR ORDER

CODICE CODE	MODELLO	TYPE
70.071.2	MIX 1 (OLIO) + 2 (EMULSIONE)	MIX 1 (OIL) + 2 (EMULSION)
70.071.3	MIX 2 (OLIO) + 2 (EMULSIONE)	MIX 2 (OIL) + 2 (EMULSION)



L'UNITA' E' FORNITA COMPLETA DI:		THE UNIT IS SUPPLIED COMPLETE OF:
1-30	LIVELLI ELETTRICI	LOW LEVEL SWITCHES
19	TAPPI DI RIEMPIMENTO CON FILTRO	FILLER CUPS + STRAINER
7	SERBATOIO 2.2 L PER EMULSIONE	2.2 L EMULSION RESERVOIR
17	SERBATOIO 1.2 L PER OLIO	1.2 L OIL RESERVOIR
12	CONTENITORE METALLICO	METALLIC BOX
9	POMPE + BASI	PUMPS + BASES
29	FILTRO ASPIRAZIONE	SUCTION STRAINER
8	REGOLATORI ARIA IMPIANTO	AIR REGULATOR
6	GENERATORE DI FREQUENZA	FREQUENCY GENERATOR
18	RACCORDO INGRESSO ARIA PUSH-IN 8 MM	AIR INLET FITTINGS PUSH-IN 8 MM
10-11	RIDUTTORE CON MANOMETRO	PRESSURE REDUCER WITH GAUGE
20	ELETTROVALVOLA 24 V DC – 24 V AC – 115 V AC O 230 V AC LA TENSIONE DEVE ESSERE AGGIUNTA AL CODICE. ESEMPIO 70.071.2.24VDC	SOLENOID VALVE 24 V DC – 24 V AC – 115 V AC OR 230 V AC THE VOLTAGE HAS TO BE ADD TO THE CODE. EXAMPLE 70.071.2.24VDC
5 M TUBO COASSIALE PER OGNI USCITA (6 MM – 2.5 MM)		5 M COAXIAL HOSE FOR EACH OUTLET (6 MM – 2.5 MM)

DIMENSIONI D'INGOMBRO

OVERALL DIMENSION

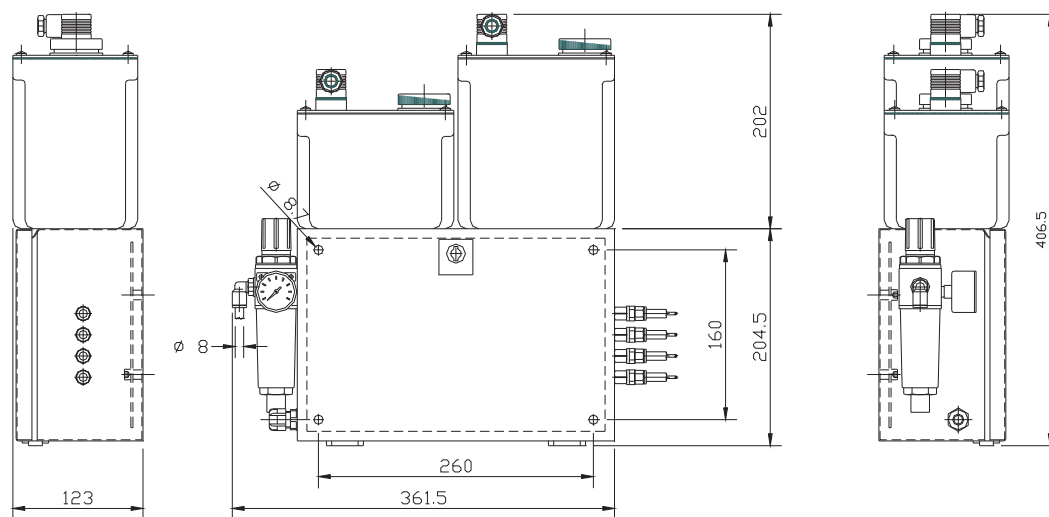

CODICI PER ORDINARE BOBINE DELL'ELETTROVALVOLA – CODES TO ORDER SOLENOID VALVE COILS

14.660.1.R	14.660.2.R	14.660.3.R	14.660.4.R
24 V DC	115 V AC	230 V AC	24 V AC





### TUBI COASSIALI

TUTTI I LUBETOOLS VENGONO FORNITI CON 5 M DI TUBO COASSIALE ASSEMBLATO ALLE USCITE DELLE POMPE PNEUMATICHE. IL TUBO DI NYLON ESTERNO HA UN DIAMETRO DI 6 MM, MENTRE QUELLO INTERNO DI 2.5 MM. IL TUBO DI NYLON INTERNO E' PIU' LUNGO DI 500 MM RISPETTO A QUELLO ESTERNO POICHE' DEVE ESSERE COLLEGATO NELLA PARTE FINALE DEL TERMINALE CON UGELLO, MENTRE QUELLO ESTERNO NELLA PARTE INIZIALE. SU RICHIESTA E' POSSIBILE FORNIRE TUBAZIONI PIU' LUNGHE E/O CON PROTEZIONI SPECIALI.

### COAXIAL FEEDING LINES

ALL LUBETOOLS ARE SUPPLIED WITH 5 M OF COAXIAL HOSES ALREADY ASSEMBLED IN THE BASE OF THE PNEUMATIC PUMPS. THE OUTSIDE NYLON HOSES HAVE A DIAMETER OF 6 MM AND THE INSIDE NYLON HOSES HAVE A DIAMETER OF 2.5 MM. THE INSIDE HOSES ARE 500 MM MORE LONGER THAN THE OUTSIDE HOSES BECAUSE HAVE TO BE JOIN TO THE NOZZLE, WHILE THE OUTSIDE HOSES HAVE TO BE JOIN TO THE STRAIGHT ADAPTORS. ON REQUEST IS POSSIBLE TO SUPPLY MORE LONGER HOSES AND/OR SPECIAL COVERING.

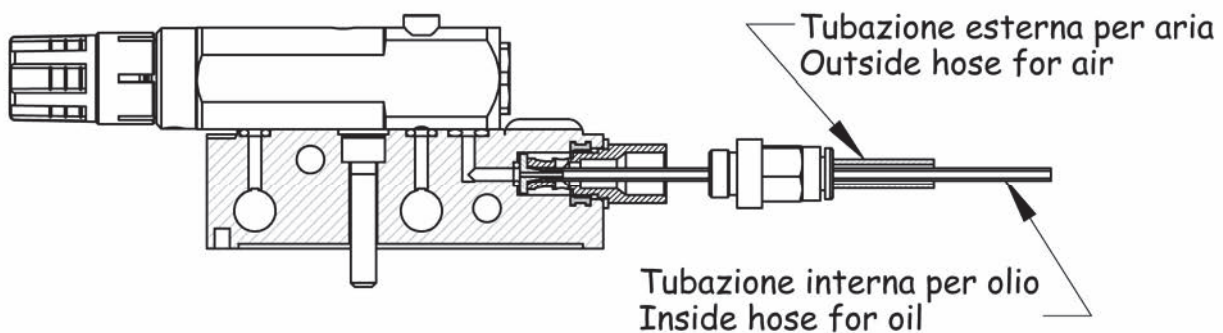

### TERMINALI CON UGELLO

I TERMINALI CON UGELLO VENGONO FORNITI CON UNA LUNGHEZZA DI 300 MM E POSSONO ESSERE RIDOTTI TAGLIANDO UNA PARTE DELLA TUBAZIONE RIGIDA O ELIMINANDO PARTI DEL LOC-LINE

### END TUBES WITH NOZZLE

THE END TUBES WITH NOZZLE HAVE AN OVERALL LENGTH OF 300 MM THAT CAN BE REDUCED CUTTING THE STEEL TUBE OR REMOVING PARTS OF THE LOC-LINE

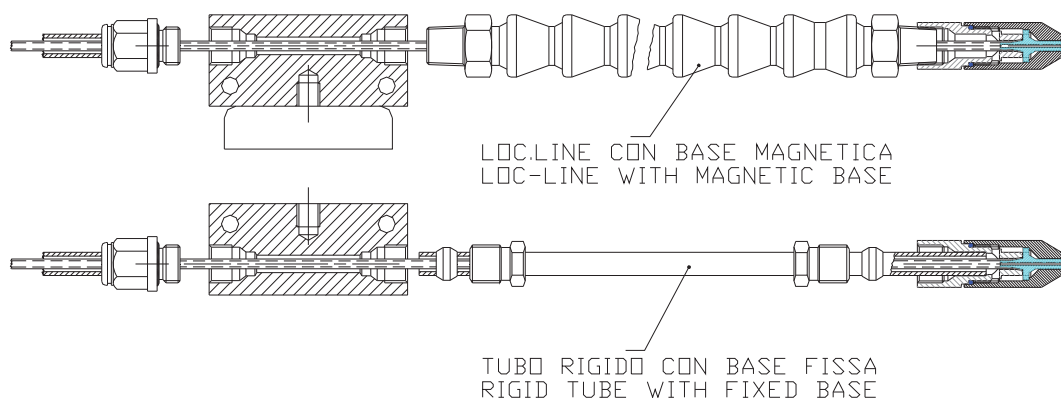

### CODICI DI ORDINAZIONE – CODES FOR ORDER

CODICE CODE	TIPO	TYPE
70.100.0	LOC-LINE CON BASE FISSA (6 MM)	LOC-LINE WITH FIXED BASE (6 MM)
70.100.2	LOC-LINE CON BASE MAGNETICA (6 MM)	LOC-LINE WITH MAGNETIC BASE (6 MM)
70.100.1	TUBO RIGIDO CON BASE FISSA (6 MM)	RIGID TUBE WITH FIXED BASE (6 MM)
70.100.3	TUBO RIGIDO CON BASE MAGNETICA (6 MM)	RIGID TUBE WITH MAGNETIC BASE (6 MM)
70.101.0	LOC-LINE CON BASE FISSA (8 MM)	LOC-LINE WITH FIXED BASE (8 MM)
70.101.2	LOC-LINE CON BASE MAGNETICA (8 MM)	LOC-LINE WITH MAGNETIC BASE (8 MM)
70.101.1	TUBO RIGIDO CON BASE FISSA (8 MM)	RIGID TUBE WITH FIXED BASE (8 MM)
70.101.3	TUBO RIGIDO CON BASE MAGNETICA (8 MM)	RIGID TUBE WITH MAGNETIC BASE (8 MM)

IL CODICE INCLUDE L'UGELLO, IL TUBO RIGIDO O IL LOC-LINE E LA BASE FISSA O MAGNETICA

THE CODE INCLUDES THE NOZZLE, THE STEEL OR THE LOC-LINE TUBE AND THE MAGNETIC OR FIXED BASE.

#### UGELLI CON TESTA FILETTATA 1/8" GAS

#### NOZZLE WITH HEAD THREAD 1/8" GAS

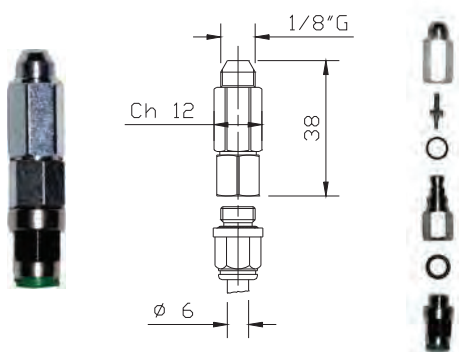

A70.093181

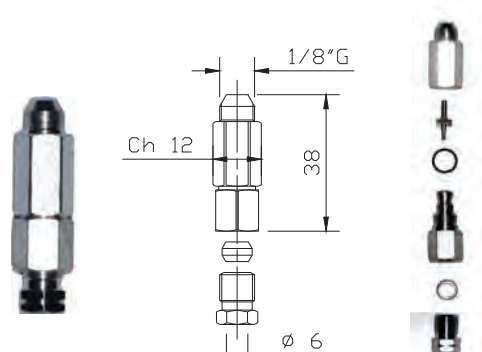

A70.093178

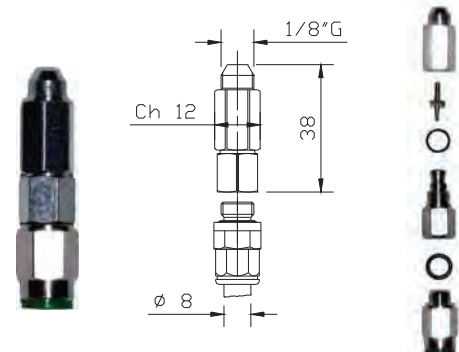

A70.093246

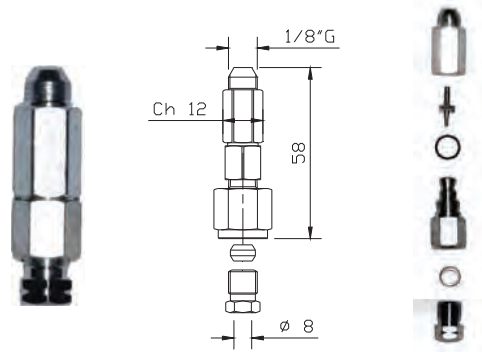

A70.093248



## TERMINALI CON UGELLO DIMENSIONI D'INGOMBRO

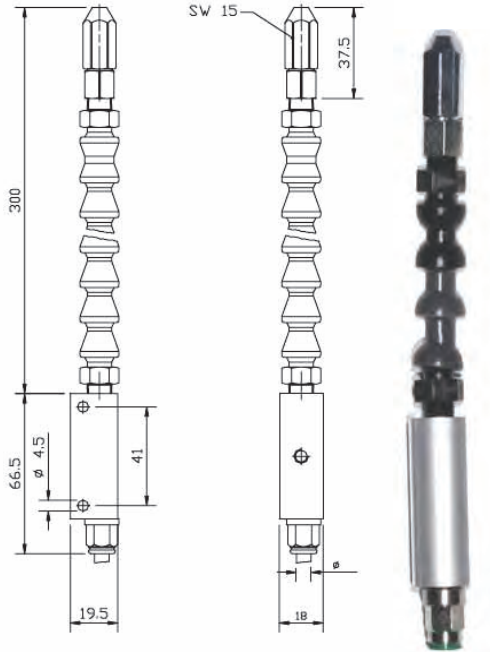

70.100.0 (Ø6)  
70.101.0 (Ø8)

## END TUBES WITH NOZZLE OVERALL DIMENSION

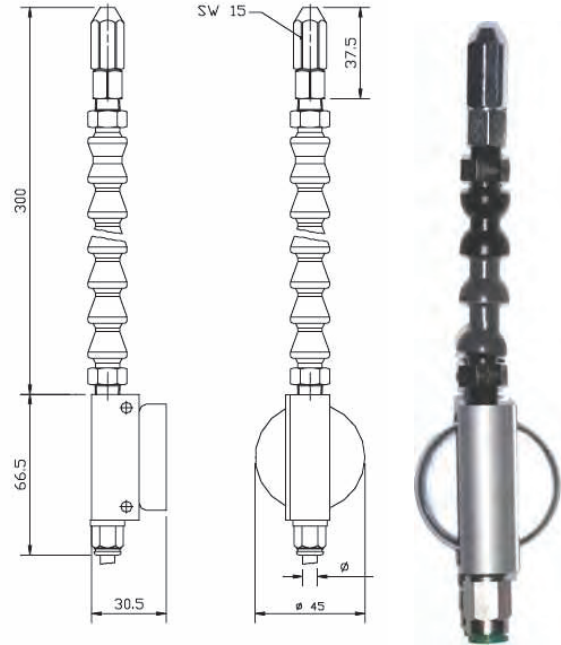

70.100.2 (Ø6)  
70.101.2 (Ø8)

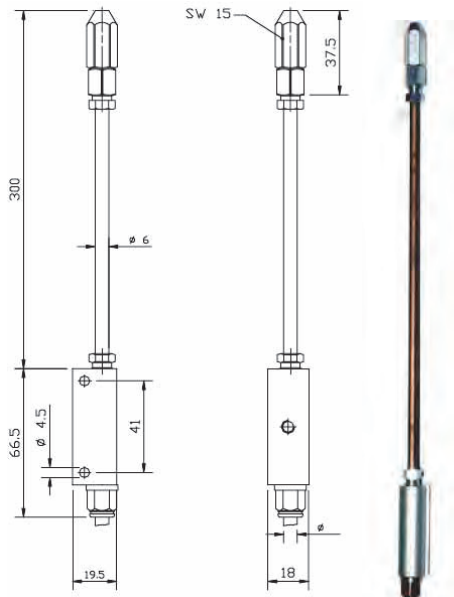

70.100.1 (Ø6)  
70.101.1 (Ø8)

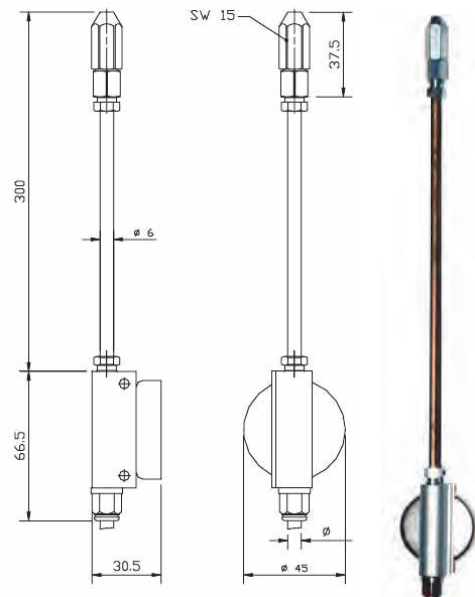

70.100.3 (Ø6)  
70.101.3 (Ø8)



## TERMINALI CON UGELLO DIMENSIONI D'INGOMBRO

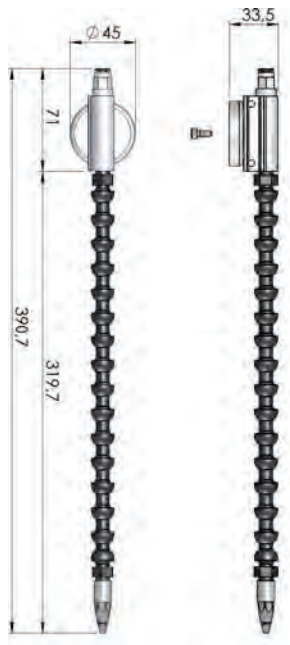

70.120.1 (Ø6)  
70.121.7 (Ø8)

## END TUBES WITH NOZZLE OVERALL DIMENSION

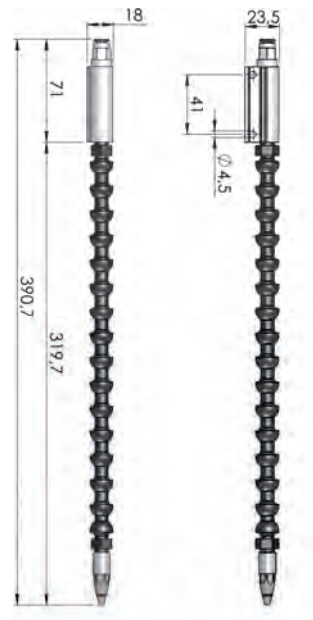

70.121.8 (Ø6)  
70.121.9 (Ø8)

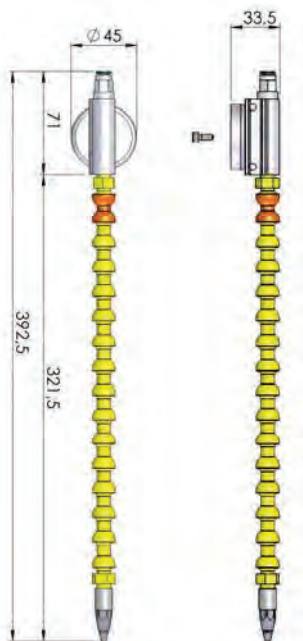

70.122.0 (Ø6)  
70.122.2 (Ø8)

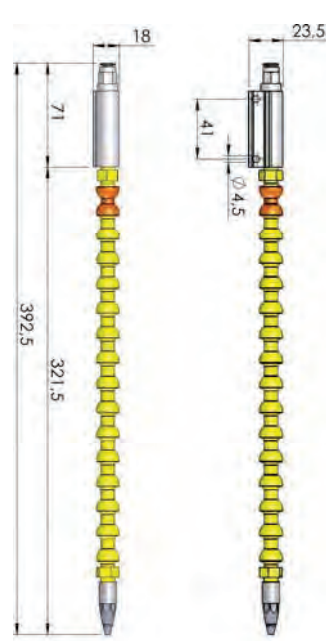

70.122.1 (Ø6)  
70.122.3 (Ø8)

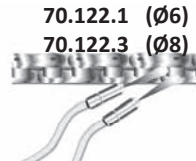
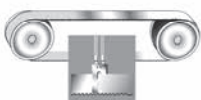

**TERMINALI CON UGELLO  
DIMENSIONI D'INGOMBRO**

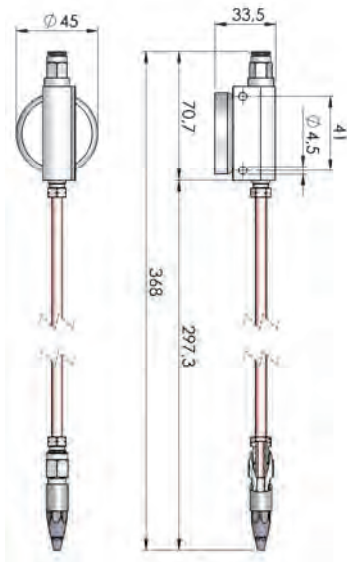

70.122.4 (Ø6)  
70.122.6 (Ø8)

**END TUBES WITH NOZZLE  
OVERALL DIMENSION**

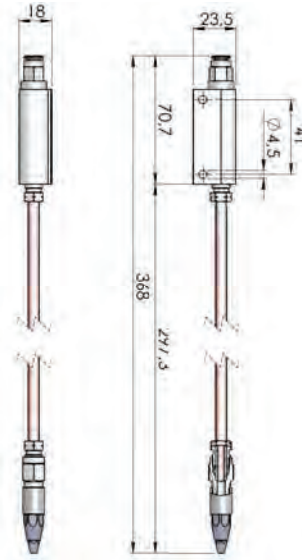

70.122.5 (Ø6)  
70.122.7 (Ø8)

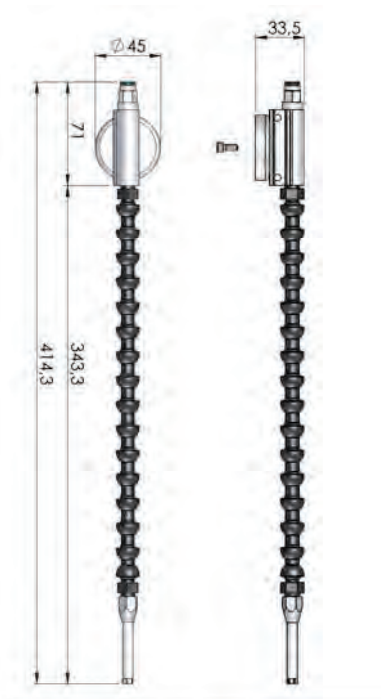

70.122.8 (Ø6)  
70.123.0 (Ø8)

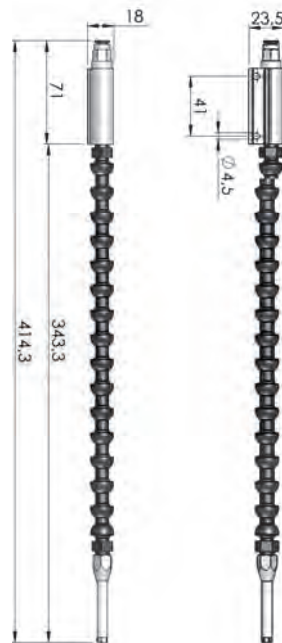

70.122.9 (Ø6)  
70.123.1 (Ø8)

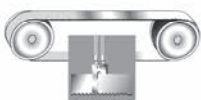



**TERMINALI CON UGELLO  
DIMENSIONI D'INGOMBRO**

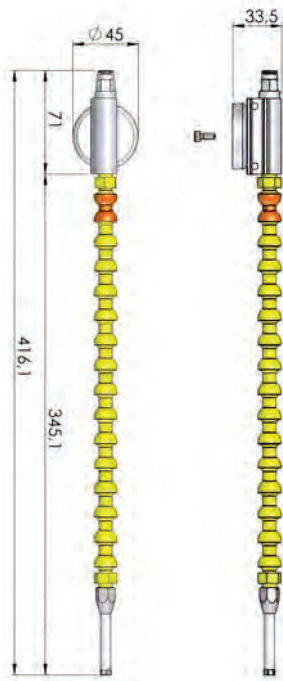

70.123.2 (Ø6)  
70.123.4 (Ø8)

**END TUBES WITH NOZZLE  
OVERALL DIMENSION**

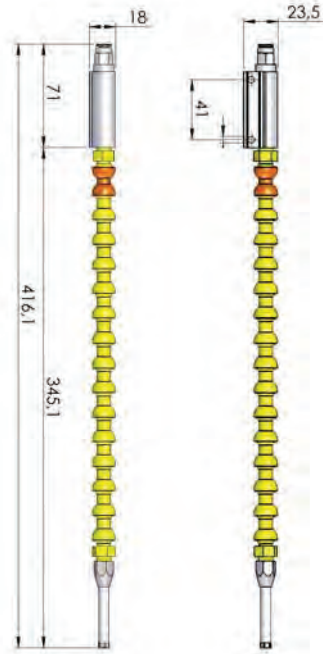

70.123.3 (Ø6)  
70.123.5 (Ø8)

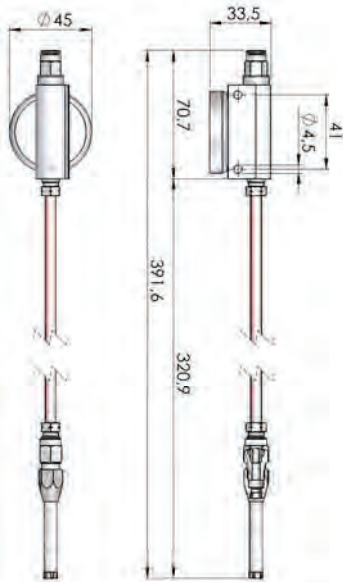

70.123.6 (Ø6)  
70.123.8 (Ø8)

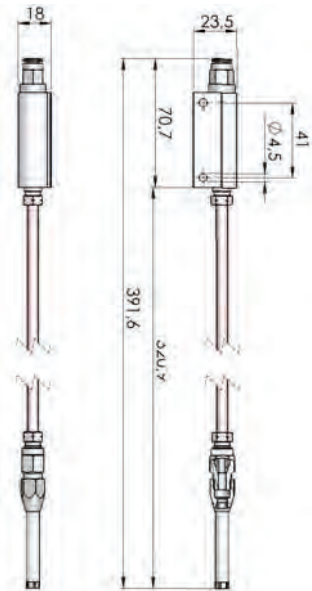

70.123.7 (Ø6)  
70.123.9 (Ø8)

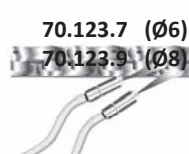
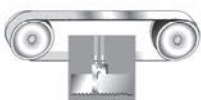



**TERMINALI CON UGELLO**  
**DIMENSIONI D'INGOMBRO**  
 CODICE  
 70.103.8

**END TUBES WITH NOZZLE**  
**OVERALL DIMENSION**  
 CODE  
 70.103.8

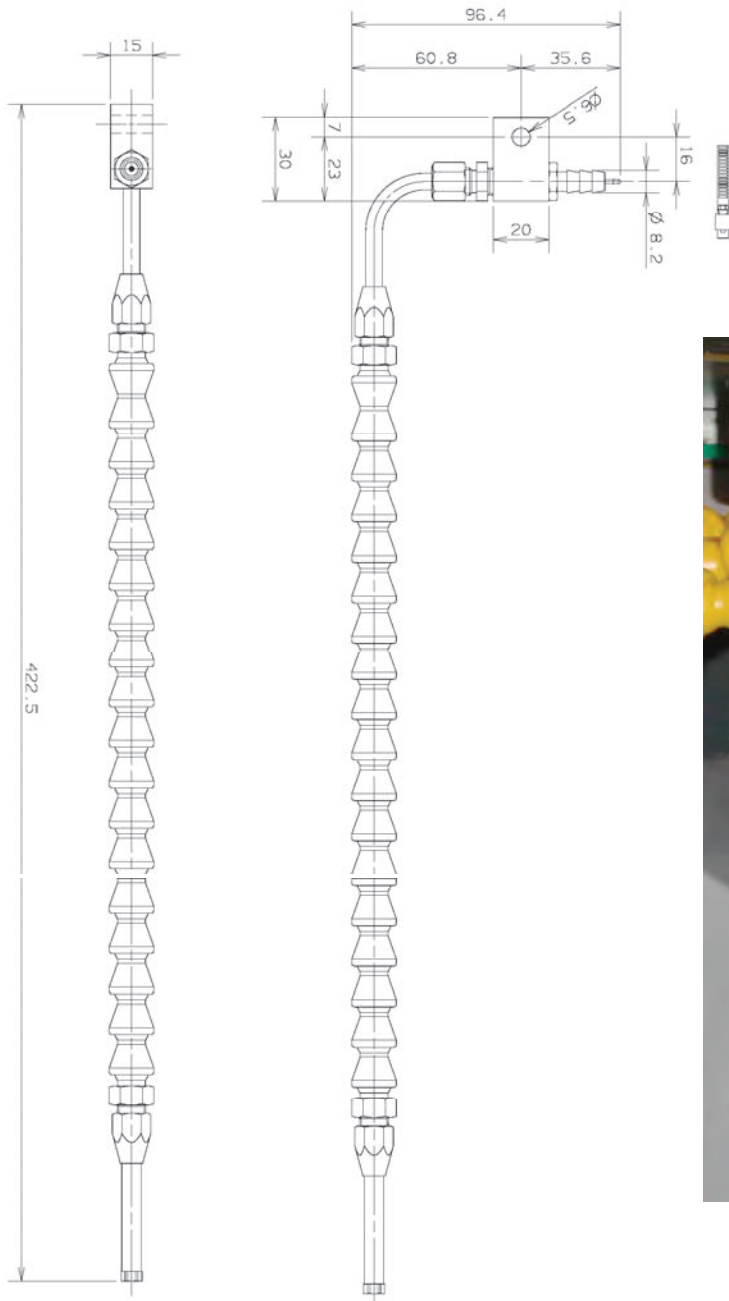

**TERMINALI CON UGELLO DECABON  
DIMENSIONI D'INGOMBRO**

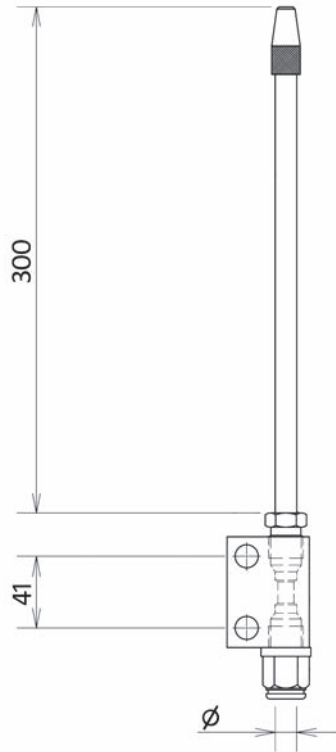

**END TUBES WITH DECABON NOZZLE  
OVERALL DIMENSION**



CODICE CODE	UGELLO DECABON DECABON NOZZLE	∅
70.118.2	CON BLOCCHETTO + RACCORDO RAPIDO / WITH BLOCK + PUSH-IN FITTING	6 MM
70.118.3	CON BLOCCHETTO MAGNETICO + RACCORDO RAPIDO / WITH MAGNETIC BLOCK + PUSH-IN FITTING	6 MM
70.118.4	CON BLOCCHETTO + RACCORDO RAPIDO / WITH BLOCK + PUSH-IN FITTING	8 MM
70.118.5	CON BLOCCHETTO MAGNETICO + RACCORDO RAPIDO / WITH MAGNETIC BLOCK + PUSH-IN FITTING	8 MM



**UGELLI A SELLA PER SEGATRICI ORIZZONTALI**  
**ALTEZZA LAMA: DA 6 MM A 34 MM**  
**LUBRIFICANTE: OLIO**

**SADDLE NOZZLE FOR HORIZONTAL BAND SAW**  
**BLADE HEIGHT: FROM 6 MM TO 34 MM**  
**LUBRICANT: OIL**

CODICE CODE	INGRESSI INLETS	USCITE OUTLETS
70.111.0	1	3

DIMENSIONI D'INGOMBRO

OVERALL DIMENSION

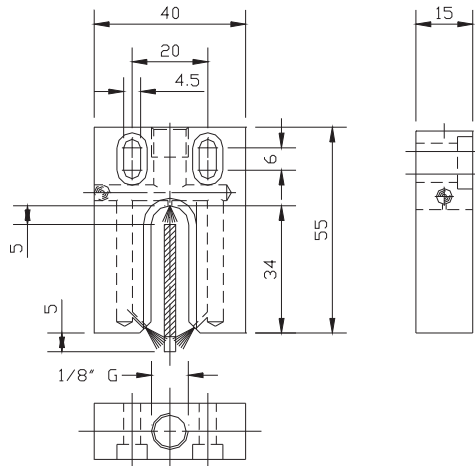

**ALTEZZA LAMA: DA 41 MM A 80 MM**  
**LUBRIFICANTE: OLIO**

**BLADE HEIGHT: FROM 41 MM TO 80 MM**  
**LUBRICANT: OIL**

CODICE CODE	INGRESSI INLETS	USCITE OUTLETS	LAMA BLADE	A	B	C
70.111.1	2	5	41	41	39	60
70.111.2	2	5	54	54	52	73
70.111.3	2	5	67	67	65	86
70.111.4	2	5	80	80	78	99

DIMENSIONI D'INGOMBRO

OVERALL DIMENSION

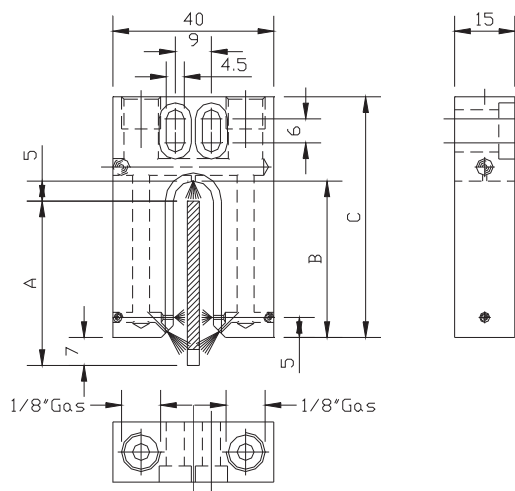

**UGELLI A SELLA PER SEGATRICI VERTICALI**  
**ALTEZZA LAMA: DA 6 MM A 34 MM**  
 LUBRIFICANTE: OLIO

**SADDLE NOZZLE FOR VERTICAL BAND SAW**  
**BLADE HEIGHT: FROM 6 MM TO 34 MM**  
 LUBRICANT: OIL

CODICE CODE	INGRESSI INLETS	USCITE OUTLETS
70.112.0	1	3

DIMENSIONI D'INGOMBRO

OVERALL DIMENSION

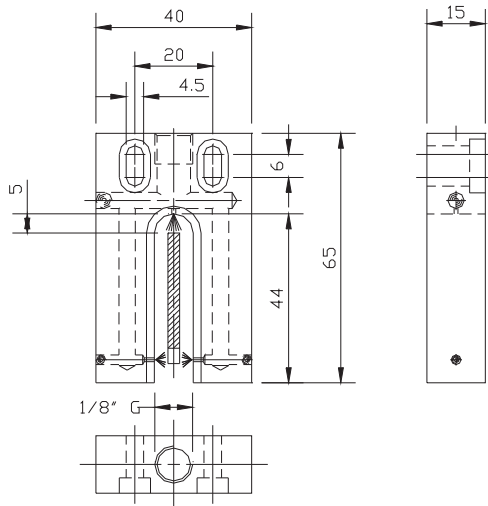

**ALTEZZA LAMA: DA 41 MM A 80 MM**  
 LUBRIFICANTE: OLIO

**BLADE HEIGHT: FROM 41 MM TO 80 MM**  
 LUBRICANT: OIL

CODICE CODE	INGRESSI INLETS	USCITE OUTLETS	LAMA BLADE	A	B	C
70.112.1	2	5	41	41	49	70
70.112.2	2	5	54	54	62	83
70.112.3	2	5	67	67	75	96
70.112.4	2	5	80	80	88	109

DIMENSIONI D'INGOMBRO

OVERALL DIMENSION

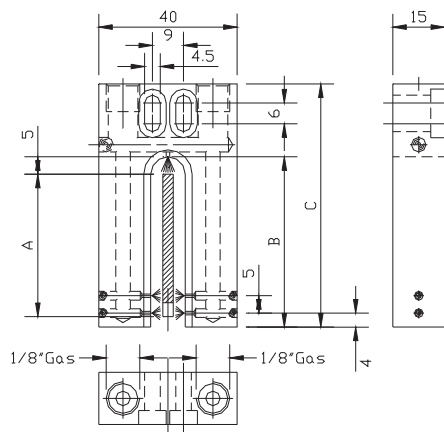

**UGELLI A SELLA PER SEGATRICI ORIZZONTALI**  
**ALTEZZA LAMA: DA 6 MM A 34 MM**  
**LUBRIFICANTE: EMULSIONE**

**SADDLE NOZZLE FOR HORIZONTAL BAND SAW**  
**BLADE HEIGHT: FROM 6 MM TO 34 MM**  
**LUBRICANT: EMULSION**

CODICE <i>CODE</i>	INGRESSI <i>INLETS</i>	USCITE <i>OUTLETS</i>
70.113.0	2	6

DIMENSIONI D'INGOMBRO

OVERALL DIMENSION

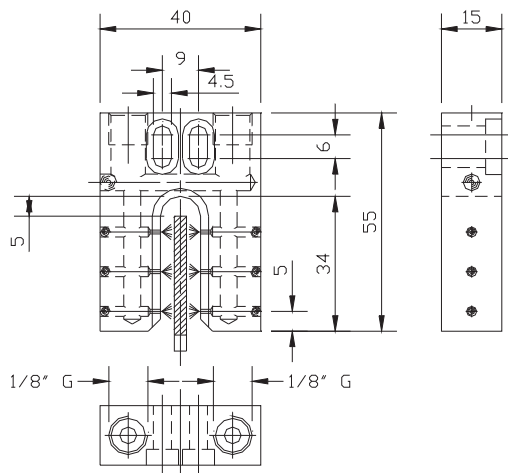

**ALTEZZA LAMA: DA 41 MM A 80 MM**  
**LUBRIFICANTE: EMULSIONE**

**BLADE HEIGHT: FROM 41 MM TO 80 MM**  
**LUBRICANT: EMULSION**

CODICE <i>CODE</i>	INGRESSI <i>INLETS</i>	USCITE <i>OUTLETS</i>	LAMA BLADE	A	B	C
70.113.1	2	6	41	41	39	60
70.113.2	2	8	54	54	52	73
70.113.3	2	10	67	67	65	86
70.113.4	2	12	80	80	78	99

DIMENSIONI D'INGOMBRO

OVERALL DIMENSION

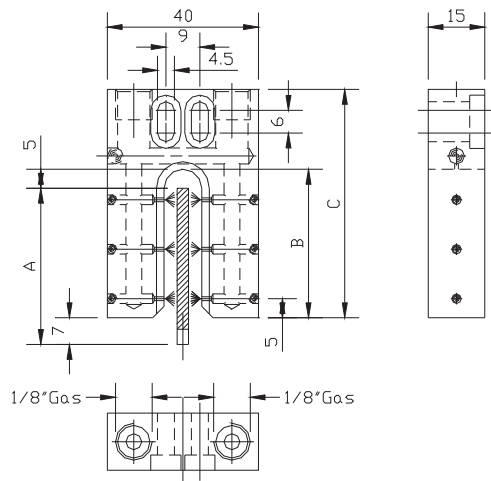

**UGELLI A SELLA PER SEGATRICI VERTICALI**  
**ALTEZZA LAMA: DA 6 MM A 34 MM**  
**LUBRIFICANTE: EMULSIONE**

**SADDLE NOZZLE FOR VERTICAL BAND SAW**  
**BLADE HEIGHT: FROM 6 MM TO 34 MM**  
**LUBRICANT: EMULSION**

CODICE <i>CODE</i>	INGRESSI <i>INLETS</i>	USCITE <i>OUTLETS</i>
70.114.0	2	6

DIMENSIONI D'INGOMBRO

OVERALL DIMENSION

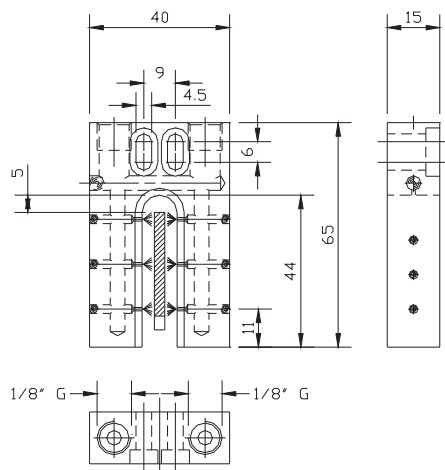

**ALTEZZA LAMA: DA 41 MM A 80 MM**  
**LUBRIFICANTE: EMULSIONE**

**BLADE HEIGHT: FROM 41 MM TO 80 MM**  
**LUBRICANT: EMULSION**

CODICE <i>CODE</i>	INGRESSI <i>INLETS</i>	USCITE <i>OUTLETS</i>	LAMA BLADE	A	B	C
70.114.1	2	6	41	41	49	70
70.114.2	2	8	54	54	62	83
70.114.3	2	10	67	67	75	96
70.114.4	2	12	80	80	88	109

DIMENSIONI D'INGOMBRO

OVERALL DIMENSION

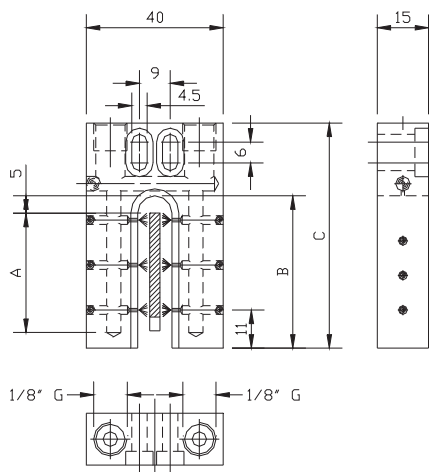



**UGELLI A SELLA PER SEGATRICI CIRCOLARI**  
LUBRIFICANTE: OLIO

**SADDLE NOZZLE FOR CIRCULAR SAW**  
LUBRICANT: OIL

CODICE CODE	INGRESSI INLETS	USCITE OUTLETS
70.106.2	2	5

DIMENSIONI D'INGOMBRO      OVERALL DIMENSION

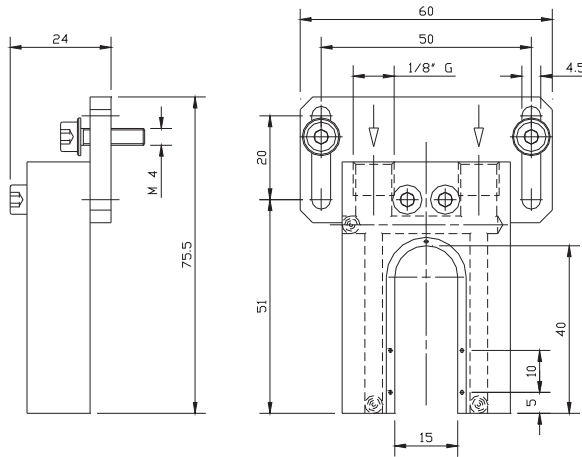

CODICE CODE	INGRESSI INLETS	USCITE OUTLETS	CODICE CODE	INGRESSI INLETS	USCITE OUTLETS
70.103.2	1	3	70.103.5	1	3

DIMENSIONI D'INGOMBRO      OVERALL DIMENSION

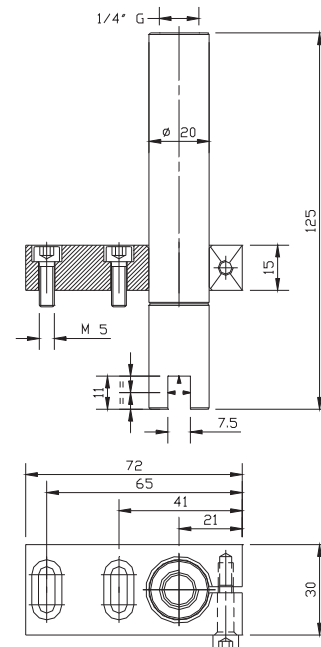
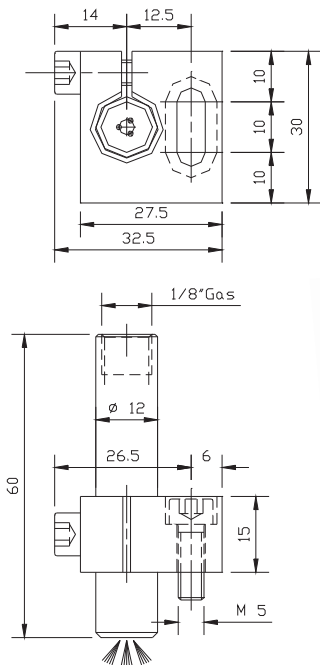

## UGELLI PER SEGATRICI CIRCOLARI

LUBRIFICANTE: OLIO + EMULSIONE

## NOZZLE FOR CIRCULAR SAW

LUBRICANT: OIL + EMULSION

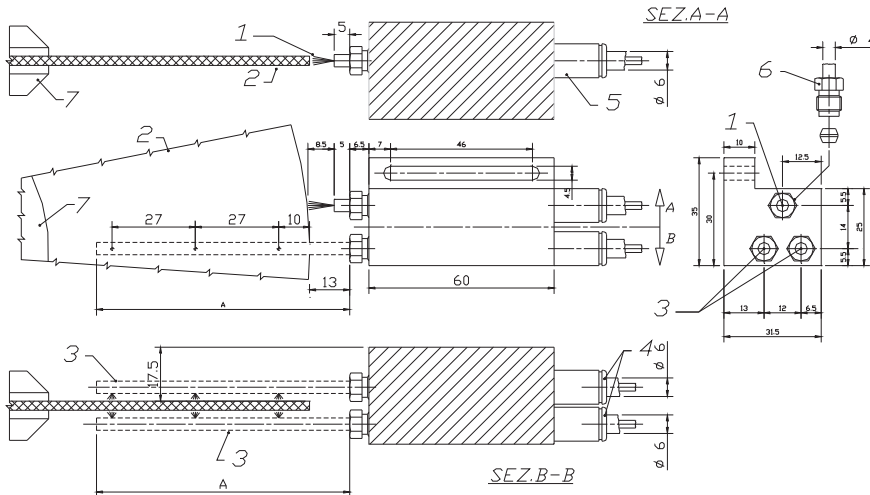

1	LUBRIFICAZIONE DENTE CON OLIO	TOOTH LUBRICATION WITH OIL
2	DISCO	DISK
3	LUBRIFICAZIONE FIANCHI CON EMULSIONE	SIDES LUBRICATION WITH EMULSION
4	RACCORDI RAPIDI TUBI 6 MM PER EMULSIONE	PUSH-IN FITTINGS TUBE 6 MM FOR EMULSION
5	RACCORDO RAPIDO TUBO 6 MM PER OLIO	PUSH-IN FITTING TUBE 6 MM FOR OIL
6	RACCORDO ED ANELLO PER TUBO 4 MM	NUT AND OLIVE FOR 4 MM TUBE
7	GHIERA DI FISSAGGIO DISCO	METAL RING TO FIX THE DISK

### CODICI DI ORDINAZIONE

### CODES FOR ORDER

CODICE CODE	FORI PER EMULSIONE EMULSION HOLES	DIAMETRO DISCO MM DISK DIAMETER MM	A
70.103.4.55	2 + 2	175 – 200	55
70.103.4.82	3 + 3	225 – 250 – 275	82
70.103.4.109	4 + 4	300 – 315 – 350 – 370 - 400	109



**UGELLO SPECIALE PER SEGATRICI VERTICALI**  
DIMENSIONI D'INGOMBRO

CODICE  
70.109.9

**SPECIAL NOZZLE FOR VERTICAL BLADE**  
OVERALL DIMENSION

CODE  
70.109.9

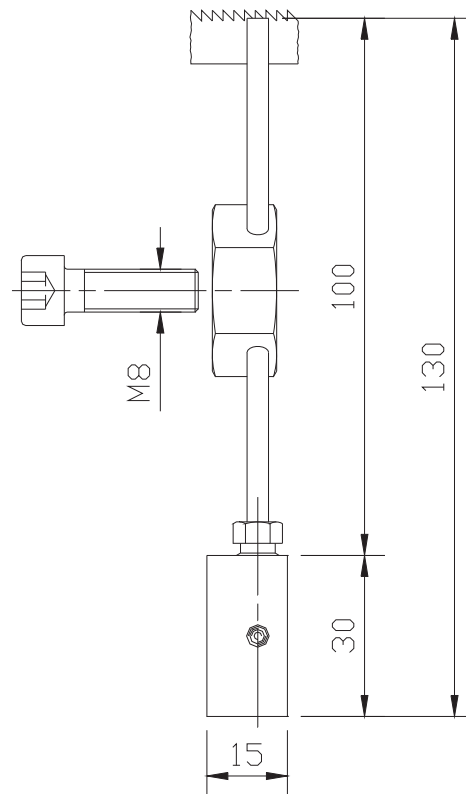
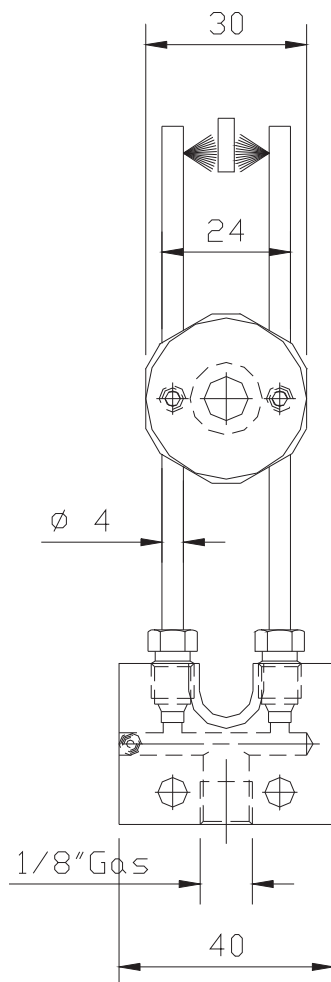
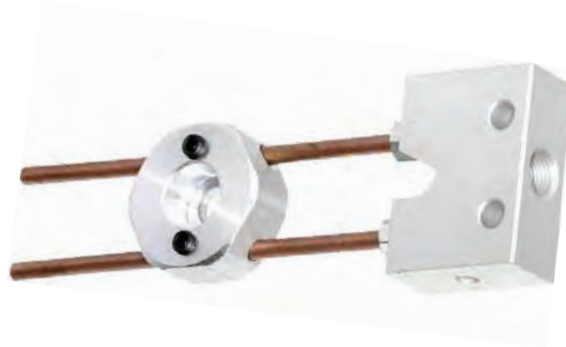

## RACCORDI RAPIDI E TAPPI PER UGELLI A SELLA

## PUSH-IN FITTINGS AND PLUG FOR SADDLE NOZZLE

A92.087058  
1/8"

A92.106113  
1/8" – 6 MM

A92.106074  
1/8" – 8 MM

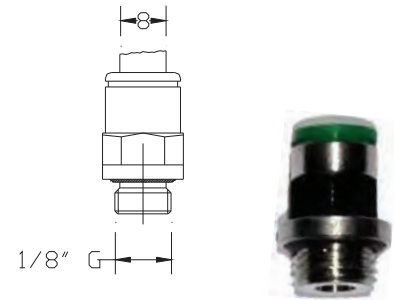
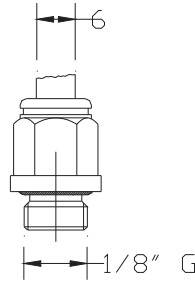
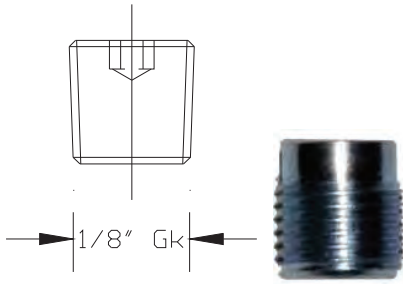

## PASSAPARETE CON RACCORDI RAPIDI PER TUBO COASSIALE 8x4 MM – 3x1.5 MM

## BULKHEAD CONNECTION PUSH-IN FOR COAXIAL HOSES 8x4 MM – 3x1.5 MM

A70.093230

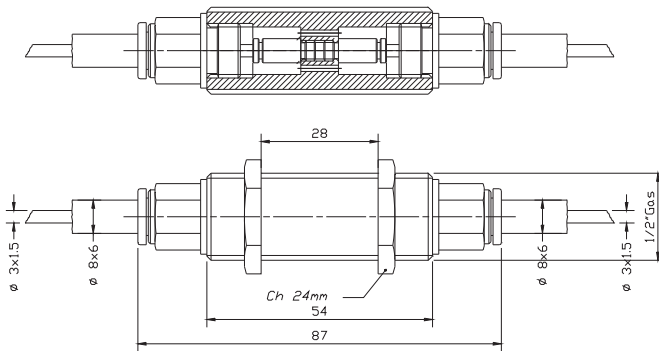

A70.093231

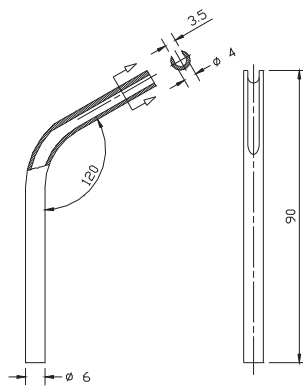

## APPLICAZIONI

RICORDA CHE TROPPO OLIO NON AIUTA, USARE GOCCE NON LITRI

SEGATRICI A NASTRO  
BAND SAW MACHINES

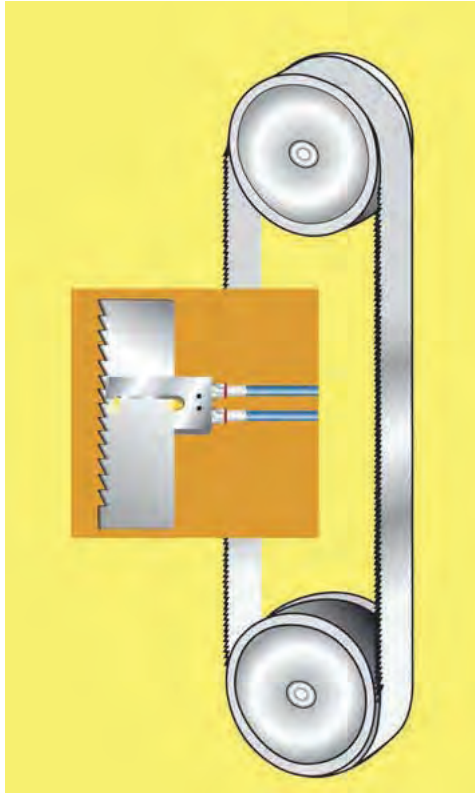

IL NUMERO DEGLI UGELLI DA UTILIZZARE DIPENDE DAI MATERIALI E DAL TIPO DI LAVORAZIONE

GUIDA PER LA SCELTA DEGLI UGELLI  
SEGATRICI A NASTRO

LAMA DA 6 MM A 34 MM	1 INGRESSO – 3 USCITE	BLADE FROM 6 MM TO 34 MM	1 INLET – 3 OUTLETS
LAMA DA 41 MM A 80 MM	2 INGRESSI – 5 USCITE	BLADE FROM 41 MM TO 80 MM	2 INLETS – 5 OUTLETS

GUIDA PER LA SCELTA DEGLI UGELLI  
SEGATRICI A DISCO

DISCO DA 175 MM A 225 MM	1 INGRESSO – 3 USCITE	DISK FROM 175 MM TO 225 MM	1 INLET – 3 OUTLETS
DISCO DA 250 MM A 400 MM	2 INGRESSI – 5 USCITE	DISK FROM 250 MM TO 400 MM	2 INLETS – 5 OUTLETS

## APPLICATIONS

REMEMBER MORE IS NOT BETTER AND USE DROPS NOT LITRES

SEGATRICI CIRCOLARI  
CIRCULAR SAW MACHINES



THE NUMBER OF NOZZLE TO USE IS DEPENDING ON THE MATERIALS AND THE ART OF PROCESSING

GUIDE TO SELECT THE NOZZLE  
BAND SAW MACHINES

GUIDE TO SELECT THE NOZZLE  
CIRCULAR SAW MACHINES



## APPLICAZIONI

RICORDA CHE TROPPO OLIO NON AIUTA, USARE GOCCE NON LITRI

### MASCHIATURA TAPPING

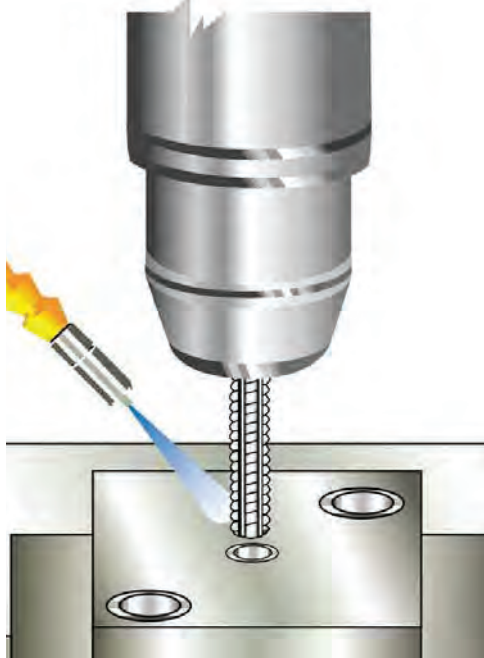

IL NUMERO DEGLI UGELLI DA UTILIZZARE DIPENDE DAI MATERIALI E DAL TIPO DI LAVORAZIONE

### GUIDA PER LA SCELTA DEGLI UGELLI MASCHIATURA

UTENSILE DA 3 MM A 10 MM	1 UGELLO	TOOL FROM 3 MM TO 10 MM	1 NOZZLE
UTENSILE DA 11 MM A 20 MM	2 UGELLI	TOOL FROM 11 MM TO 20 MM	2 NOZZLE
UTENSILE DA 21 MM A 40 MM	3 UGELLI	TOOL FROM 21 MM TO 40 MM	3 NOZZLE
UTENSILE DA 41 MM A 60 MM	4 UGELLI	TOOL FROM 41 MM TO 60 MM	4 NOZZLE

### GUIDA PER LA SCELTA DEGLI UGELLI FORATURA - ALESATURA

UTENSILE DA 1 MM A 12 MM	1 UGELLO	TOOL FROM 1 MM TO 12 MM	1 NOZZLE
UTENSILE DA 13 MM A 24 MM	2 UGELLI	TOOL FROM 13 MM TO 24 MM	2 NOZZLE
UTENSILE DA 25 MM A 48 MM	3 UGELLI	TOOL FROM 25 MM TO 48 MM	3 NOZZLE
UTENSILE DA 49 MM A 60 MM	4 UGELLI	TOOL FROM 49 MM TO 60 MM	4 NOZZLE

## APPLICATIONS

REMEMBER MORE IS NOT BETTER AND USE DROPS NOT LITRES

### FORATURA - ALESATURA DRILLING - BORING



THE NUMBER OF NOZZLE TO USE IS DEPENDING ON THE MATERIALS AND THE ART OF PROCESSING

### GUIDE TO SELECT THE NOZZLE TAPPING

### GUIDE TO SELECT THE NOZZLE DRILLING - BORING





## APPLICAZIONI

RICORDA CHE TROPPO OLIO NON AIUTA, USARE GOCCE NON LITRI

## APPLICATIONS

REMEMBER MORE IS NOT BETTER AND USE DROPS NOT LITRES

FRESATURA – INCISIONE  
MILLING - ENGRAVING

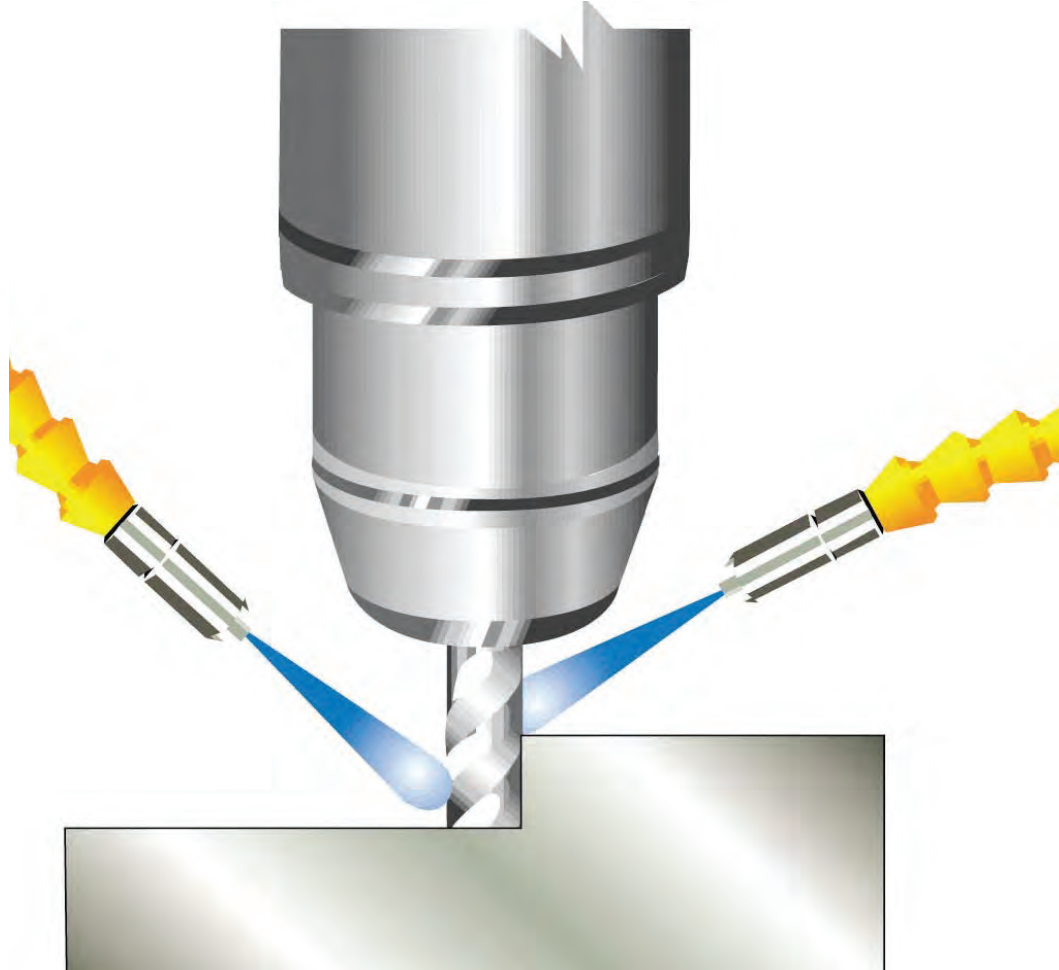

IL NUMERO DEGLI UGELLI DA UTILIZZARE DIPENDE DAI MATERIALI E DAL TIPO DI LAVORAZIONE

GUIDA PER LA SCELTA DEGLI UGELLI

THE NUMBER OF NOZZLE TO USE IS DEPENDING ON THE MATERIALS AND THE ART OF PROCESSING

GUIDE TO SELECT THE NOZZLE

UTENSILE DA 1 MM A 12 MM	1 UGELLO	TOOL FROM 1 MM TO 12 MM	1 NOZZLE
UTENSILE DA 13 MM A 40 MM	2 UGELLI	TOOL FROM 13 MM TO 40 MM	2 NOZZLE
UTENSILE DA 41 MM A 100 MM	3 UGELLI	TOOL FROM 41 MM TO 100 MM	3 NOZZLE
UTENSILE DA 101 MM A 240 MM	4 UGELLI	TOOL FROM 101 MM TO 240 MM	4 NOZZLE





Il SISTEMA DI LUBRIFICAZIONE PER LA LAVORAZIONE DEI TUBI consiste di svariate opzioni, a seconda delle preferenze del cliente.

Normalmente il mandrino è lubrificato con una quantità di olio e una pressione dell'aria più alta rispetto agli altri punti. Lo spruzzo dispensato da ogni uscita è completamente regolabile. Il cliente può avere una combinazione di aria-olio o solo olio.

Possiamo configurare il sistema seguendo le esigenze del cliente.

Un'esatta quantità regolabile di lubrificante è mandata a tutti i punti che devono essere lubrificati. L'intero ambiente di lavoro rimane pulito.

### BENEFICI:

- La quantità di lubrificante che viene spruzzata è molto precisa
- Ripetizione dei cicli in automatico
- È possibile configurare il sistema automatizzandolo con la macchina
- Varie combinazioni di uscite
- Sistemi progettati e prodotti per soddisfare le richieste del cliente
- Regolazione della quantità di aria ed olio per ogni punto di lubrificazione

The **TUBE FORMING LUBRICATION SYSTEM** consists of many options, it depends on customer preferences.

Normally the mandrel is lubricated with higher oil volume and higher air pressure than the other points. The spray dispensed to each outlet is fully adjustable. The customer can have an air-oil combination or just oil.

We can set the system following customers need.

An exact adjustable amount of lubricant is sent to all points that have to be lubricate. The whole working environment remains clean.

### BENEFITS:

- Positive lubricant injection
- Automatic repeat cycling of lubricant metering pumps
- Automatic cycling with machine
- Various combination of outlets
- Custom systems to meet customer's needs
- Full adjustment of air and oil output at each lubrication point



## APPLICAZIONI

RICORDA CHE TROPPO OLIO NON AIUTA, USARE GOCCE NON LITRI

LAVORAZIONE DEI TUBI

TAGLIO TRADIZIONALE  
TAGLIO ORBITALE  
TRANCIATURA  
RASTREMATURA

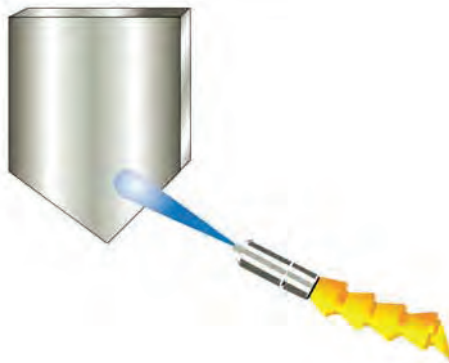

## APPLICATIONS

REMEMBER MORE IS NOT BETTER AND USE DROPS NOT LITRES

TUBE FABRICATION

TRADITIONAL CUTTING  
ORBITAL CUTTING  
SHEARING  
TAGGING

PUNZONATURA  
FORATURA  
INTESTATURA  
SVASATURA

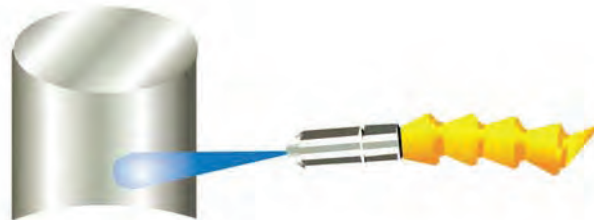

PUNCHING  
DRILLING  
FACING  
FLARING

FORMATURA  
PIEGATURA – CURVATURA  
SAGOMATURA

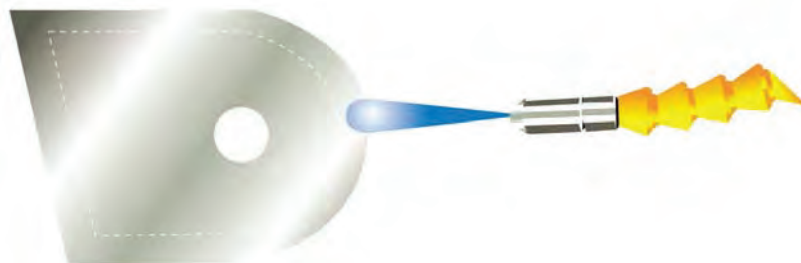

FORMING  
BENDING  
SHAPING

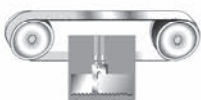

## APPLICAZIONI

RICORDA CHE TROPPO OLIO NON AIUTA, USARE GOCCE NON LITRI

CATENARIE – CONVOGLIATORI AEREI MONO E BI-ROTAIA

GARANTISCONO UNA PERFETTA LUBRIFICAZIONE DEGLI ORGANI SOGGETTI AD USURA.

NON INQUINANO I PRODOTTI TRASPORTATI CON RESIDUI O GOCCIOLAMENTI DI OLIO.

NON PRODUCONO NEBBIE O VAPORI NOCIVI.

COMPATIBILI CON LE NUOVE GENERAZIONI DI LUBRIFICANTI DEFINITI "ANTIGOCCIA O AD ALTE DENSITA'" CHE GARANTISCONO UN PERFETTO ANCORAGGIO DEL PRODOTTO.

LA SCELTA DEL MODELLO DEVE AVVENIRE IN BASE AL NUMERO DELLE UTENZE DA LUBRIFICARE.

IL CONSENSO DI FUNZIONAMENTO E' INVIATO DA UN TASTATORE MECCANICO O DA UN SENSORE INDUTTIVO CHE, AZIONATO DAL PASSAGGIO DELLA CATENA, ECCITA UNA VALVOLA E/O UNA ELETTROVALVOLA PNEUMATICA. L'APERTURA DI QUEST' ULTIMA DETERMINA LA PARTENZA DEL SISTEMA CHE, DURANTE IL TEMPO DI LAVORO, PUO' INVIARE UN SINGOLO IMPULSO O PIU' IMPULSI IN BASE ALLA CONFIGURAZIONE DELL'UNITA'.

LA DURATA DEL TEMPO DI LAVORO E' DETERMINATA DAL TEMPO DI PASSAGGIO DEL TASTATORE SULLA CATENA.

L'UGELLO NORMALMENTE UTILIZZATO TERMINA NELLA CONFIGURAZIONE CON BLOCCHETTO E TUBO RIGIDO. QUESTA SOLUZIONE PERMETTE DI SAGOMARE ED INDIRIZZARE CON PRECISIONE IL GETTO FINALE SENZA L'AUSILIO DI ALTRE STRUTTURE DI SOSTEGNO.

IN ALCUNE OCCASIONI SONO IMPIEGATI GLI UGELLI CON PUNTA FILETTATA ED IN QUESTO CASO SONO NECESSARI DEI SUPPORTI DI SOSTEGNO CON FORO FILETTATO.

## APPLICATIONS

REMEMBER MORE IS NOT BETTER AND USE DROPS NOT LITRES

CHAINS – MONO AND BI-RAIL CONVEYORS

THE LUBRICATION ASSURES MAXIMUM CHAIN LIFE AND OPTIMUM CONVEYOR OPERATION.

THE SYSTEM DOES NOT CONTAMINATE THE TRANSPORTED MATERIALS WITH OIL DROPS.

THE SYSTEM DO NOT PRODUCE FOG OR DANGEROUS VAPOUR.

LAST GENERATION OIL CAN BE USED WITHOUT PROBLEMS.

THE CORRECT UNIT DEPENDS ON THE NUMBER OF POINTS HAVE TO BE LUBRICATE.

THE UNIT WILL BEGIN TO OPERATE BY MEAN OF AN INDUCTIVE SENSOR OR A MECHANICAL FEELER PIN OPERATED FROM THE CHAIN.

A SOLENOID VALVE OR A VALVE WILL OPEN AND WILL SEND THE AIR TO THE SYSTEM.

DURING THE WORKING TIME WILL BE POSSIBLE TO HAVE ONE SHOT OR MORE SHOTS DEPENDING ON THE CHAIN HAVE TO BE LUBRICATED.

THE TIME THAT THE INDUCTIVE SENSOR OR THE MECHANICAL FEELER PIN IS ACTIVATED FROM THE CHAIN. WILL BE THE WORKING TIME.

THE MORE USED NOZZLE IS WITH STEEL UBE BECAUSE HAS THE POSSIBILITY TO BE ADJUSTED WITHOUT BRACKET.

SOME TIME ARE USED THE NOZZLE WITH A THREADED FINAL PART. IN THIS CASE HAS TO BE USED BRACKETS WITH THREAD HOLES.



SISTEMI DI LUBRIFICAZIONE PER CONVOGLIATORI

CONVEYORS LUBRICATION SYSTEMS

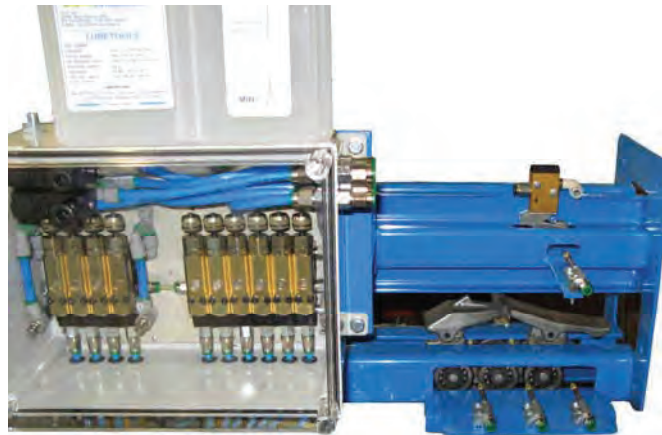



## SISTEMI DI LUBRIFICAZIONE PER CONVOGLIATORI MONO E BI ROTAIA

QUESTO SISTEMA È PROGETTATO PER LUBRIFICARE I RULLI DEI CONVOGLIATORI MENTRE SONO IN FUNZIONE E DISTRIBUISCE UNA QUANTITA' ESATTA DI LUBRIFICANTE NEI CUSCINETTI IN MOVIMENTO. QUESTI SISTEMI DI LUBRIFICAZIONE SONO PERFETTI PER APPLICAZIONI ANCHE IN CONDIZIONI DI LAVORO DIFFICILI. OGNI CONVOGLIATORE NECESSITA DI UNA UNITA' PER IL LATO SINISTRO E PER IL LATO DESTRO. LA SEQUENZA DEGLI EVENTI DI LUBRIFICAZIONE (OGNI RULLO O OGNI RULLO SUPPLEMENTARE, ECC.) DIPENDE DAL NUMERO DI RULLI, DALLA VELOCITA' DEL NASTRO O DALLA DISTANZA TRA I RULLI.

### BENEFICI

APPLICAZIONE DI UNA QUANTITA' ESATTA DI LUBRIFICANTE

LAVORA SU PARTI IN MOVIMENTO CHE RICHIEDONO MOLTO TEMPO PER LA LUBRIFICAZIONE MANUALE

LUBRIFICA MENTRE IL CONVOGLIATORE LAVORA – NESSUNA PERDITA NEI TEMPI DI PRODUZIONE

LUBRIFICA ANCHE IN CONDIZIONI DI LAVORO DIFFICILI

### FUNZIONAMENTO

IL SISTEMA È FORMATO DA UN SERBATOIO CHE INVIA OLIO, PER GRAVITA', ALLE CAMERE DI DOSAGGIO DELLE MICROPOMPE PNEUMATICHE. L'ARIA NECESSARIA PER IL FUNZIONAMENTO DELLE POMPE E PER LO SPRUZZO DELL'OLIO VIENE INVIATA AL PASSAGGIO DEI CUSCINETTI CHE AZIONANO VALVOLE PNEUMATICHE A COMANDO MECCANICO O SENSORI INDUTTIVI, POSIZIONATI OPPORTUNAMENTE LUNGO I BINARI.

## CONVEYORS LUBRICATION MONO AND BI RAIL SYSTEMS

*THIS SYSTEM IS DESIGNED TO LUBRICATE THE ROLLERS OF CONVEYORS WHILE THEY ARE IN OPERATION AND DELIVERS A METERED AMOUNT OF LUBRICANT INTO MOVING BEARING FITTINGS. THESE CUSTOM-ENGINEERED LUBRICATION SYSTEMS ARE PERFECT FOR APPLICATIONS EVEN IN HARSH OPERATING CONDITIONS.*

*EACH CONVEYOR REQUIRES ONE UNIT FOR THE LEFT SIDE AND FOR THE RIGHT.*

*THE SEQUENCE OF THE LUBRICATION EVENTS (EACH ROLLER OR EVERY OTHER ROLLER, ETC.) DEPENDS ON THE NUMBER OF ROLLERS, THE SPEED OF THE CONVEYOR OR ON THE DISTANCE BETWEEN THE ROLLERS.*

### BENEFITS

*METERED APPLICATION OF LUBRICANT*

*WORKS ON MOVING PARTS WHICH CONSUMING TIME TO LUBRICATE MANUALLY*

*LUBRICATES WHILE THE CONVEYOR IS IN NORMAL OPERATION – NO LOST PRODUCTION TIME*

*LUBRICATION EVEN UNDER HARSH OPERATION CONDITION*

### FUNCTIONING

*SYSTEM IS FORMED BY A RESERVOIR WHICH SENDS OIL, BY GRAVITY, TO THE DISPENSING ROOMS OF THE PNEUMATIC MICROPUMPS. NECESSARY AIR FOR THE FUNCTIONING OF THE PUMPS AND THE OIL SPRAY IS SENT ON THE PASSAGE OF BEARINGS THAT POWER PNEUMATIC VALVES WITH MECHANICAL CONTROL OR INDUCTIVE SENSORS, SUITABLY POSITIONED ALONG RAILROAD.*





## SISTEMI DI LUBRIFICAZIONE PER CONVOGLIATORI MONOROTAIA

## CONVEYORS LUBRICATION MONORAIL SYSTEMS

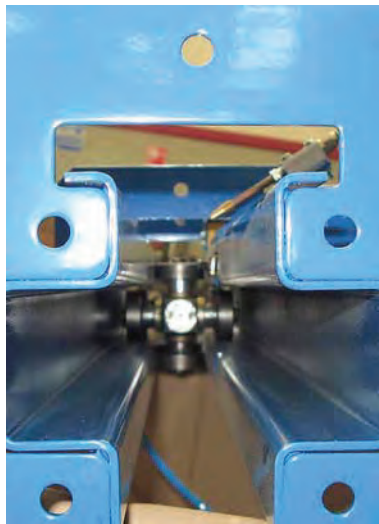

### SISTEMA TIPICO CONVOGLIATORE MONOROTAIA

### TYPICAL MONORAIL CONVEYOR SYSTEM

IL TIPICO SISTEMA PER CONVOGLIATORE MONOROTAIA È COMPOSTO DA

TYPICAL MONORAIL CONVEYOR SYSTEM IS COMPOSED BY:

- 1) 2 VALVOLE PNEUMATICHE AD AZIONAMENTO MECCANICO O 2 SENSORI INDUTTIVI
- 2) 4 MICROPOMPE DIVISE IN DUE GRUPPI DA 2
- 3) UN SERBATOIO DA 2,2 L COMPLETO DI CONTROLLO DEL LIVELLO DI LUBRIFICANTE
- 4) 2 REGOLATORI DELL'ARIA DI SPRUZZO
- 5) 4 UGELLI

- 1) 2 PNEUMATIC VALVES WITH MECHANICAL CONTROL OR 2 INDUCTIVE SENSORS
- 2) 4 MICROPUMPS DIVIDED IN TWO GROUPS OF 2
- 3) ONE 2.2 L RESERVOIR COMPLETE OF LUBRICANT LOW LEVEL SWITCH
- 4) 2 AIR REGULATORS
- 5) 4 NOZZLES

SIAMO COMUNQUE DISPONIBILI PER PROGETTARE SISTEMI SU SPECIFICA RICHIESTA DEL CLIENTE.

WE ARE STILL AVAILABLE FOR DESIGNING SYSTEMS ON SPECIFIC REQUEST OF CUSTOMER.



## SISTEMI DI LUBRIFICAZIONE PER CONVOGIATORI BIROTAIA

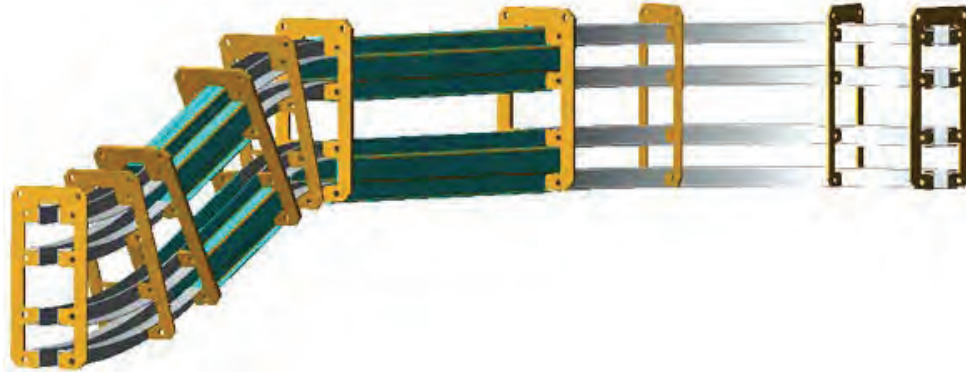

## CONVEYORS LUBRICATION BIRAIL SYSTEMS



### SISTEMA TIPICO CONVOGIATORE BIROTAIA

IL TIPICO SISTEMA PER CONVOGIATORE BIROTAIA È COMPOSTO DA:

- 1) 3 O 4 VALVOLE PNEUMATICHE AD AZIONAMENTO MECCANICO O SENSORI INDUTTIVI
- 2) 10 O PIU' MICROPOMPE DIVISE IN DUE GRUPPI DA 2 ED UNO DA 6
- 3) UN SERBATOIO DA 3,6 L COMPLETO DI CONTROLLO DEL LIVELLO DI LUBRIFICANTE
- 4) 3 O PIU' REGOLATORI DELL'ARIA DI SPRUZZO
- 5) 10 O PIU' UGELLI

SIAMO COMUNQUE DISPONIBILI PER PROGETTARE SISTEMI SU SPECIFICA RICHIESTA DEL CLIENTE.

### TYPICAL BIRAIL CONVEYOR SYSTEM

TYPICAL BIRAIL CONVEYOR SYSTEM IS COMPOSED BY:

- 1) 3 OR 4 PNEUMATIC VALVES WITH MECHANICAL CONTROL OR INDUCTIVE SENSORS
- 2) 10 OR MORE MICROPUMPS DIVIDED INTO TWO GROUPS OF 2 AND ONE OF 6
- 3) ONE 3,6L RESERVOIR COMPLETE OF LOW LEVEL SWITCH
- 4) 3 OR MORE AIR REGULATOR
- 5) 10 OR MORE NOZZLES

WE ARE STILL AVAILABLE FOR DESIGNING SYSTEMS ON SPECIFIC REQUEST OF CUSTOMER.



## APPLICAZIONI

RICORDA CHE TROPPO OLIO NON AIUTA, USARE GOCCE NON LITRI

CATENARIE – CONVOGLIATORI AEREI MONO E BI-ROTAIA

## APPLICATIONS

REMEMBER MORE IS NOT BETTER AND USE DROPS NOT LITRES

CHAINS – MONO AND BI-RAIL CONVEYORS

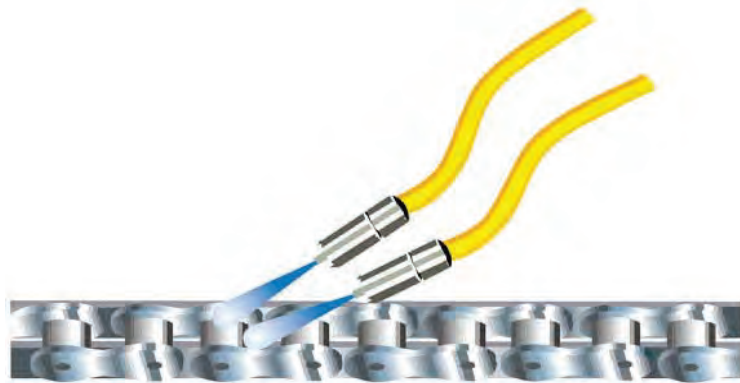
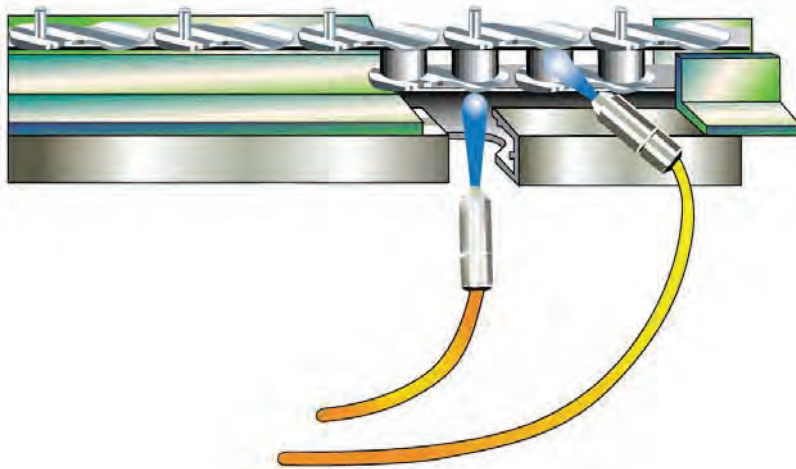

## APPLICAZIONI

RICORDA CHE TROPPO OLIO NON AIUTA, USARE GOCCE NON LITRI

STAMPAGGIO E DEFORMAZIONE A FREDDO

LUBRIFICAZIONE DEL NASTRO E DEI PUNZONI

## APPLICATIONS

REMEMBER MORE IS NOT BETTER AND USE DROPS NOT LITRES

METAL FORMING LUBRICATION

METAL FORMING LUBRICATION

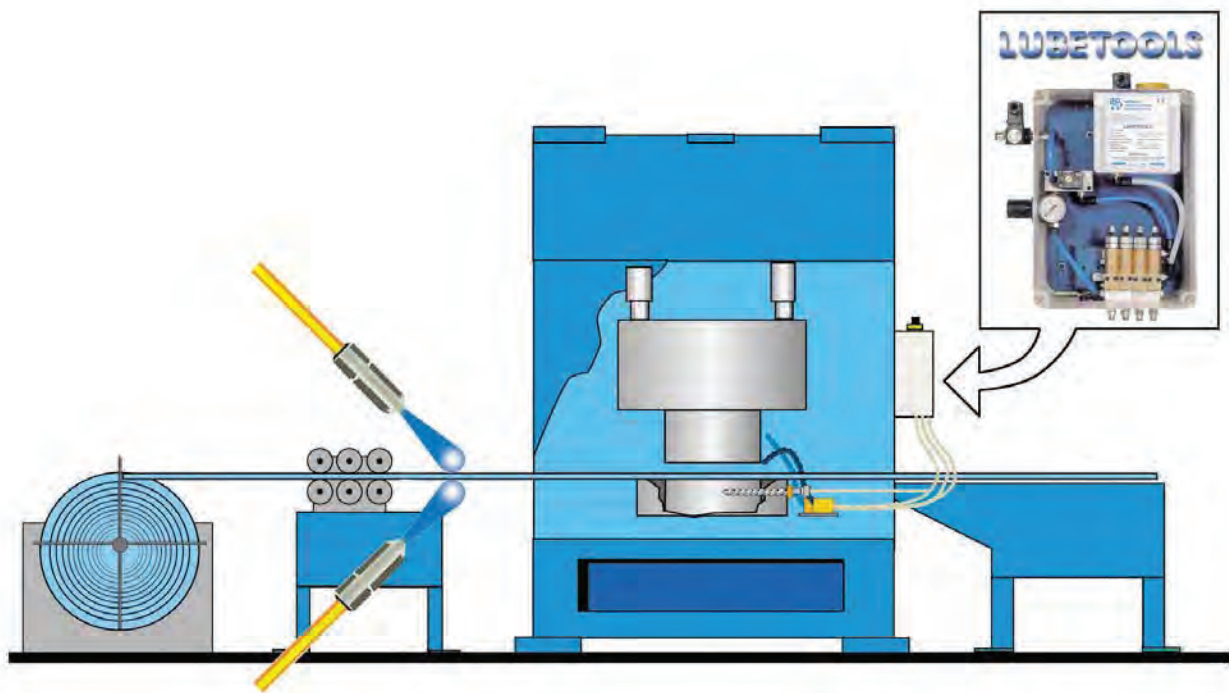



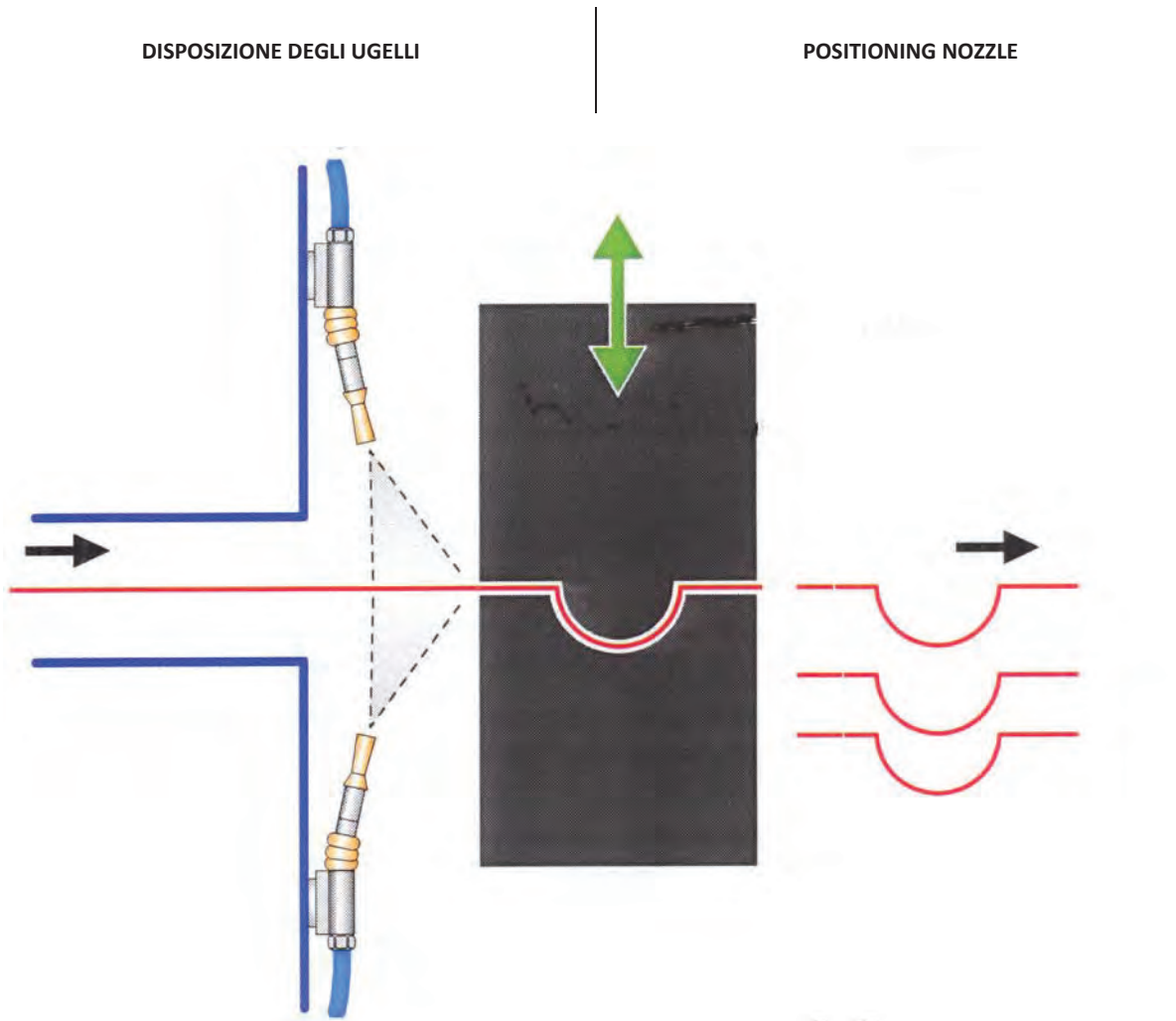

DISTANZA DAL FOGLIO 100-150 MM  
 DISTANZA DA UN ALTRO UGELLO 100 MM  
 ANGOLAZIONE 45 GRADI COME MOSTRATO IN FIGURA  
 OGNI UGELLO COPRE UNA SUPERFICIE DI 100-120 MM

*SHEET DISTANCE 100-150 MM  
 DISTANCE FROM ANOTHER NOZZLE 100 MM  
 45° ANGLE AS SHOW ON THE PICTURE  
 EACH NOZZLE COVER A SURFACE OF 100-120 MM*



LUBRIFICAZIONE SOPRA E SOTTO DI UN NASTRO CON LARGHEZZA DA 50 MM A 800 MM

STRIP TOP AND BOTTOM LUBRICATION WITH WIDTH FROM 50 MM TO 800 MM

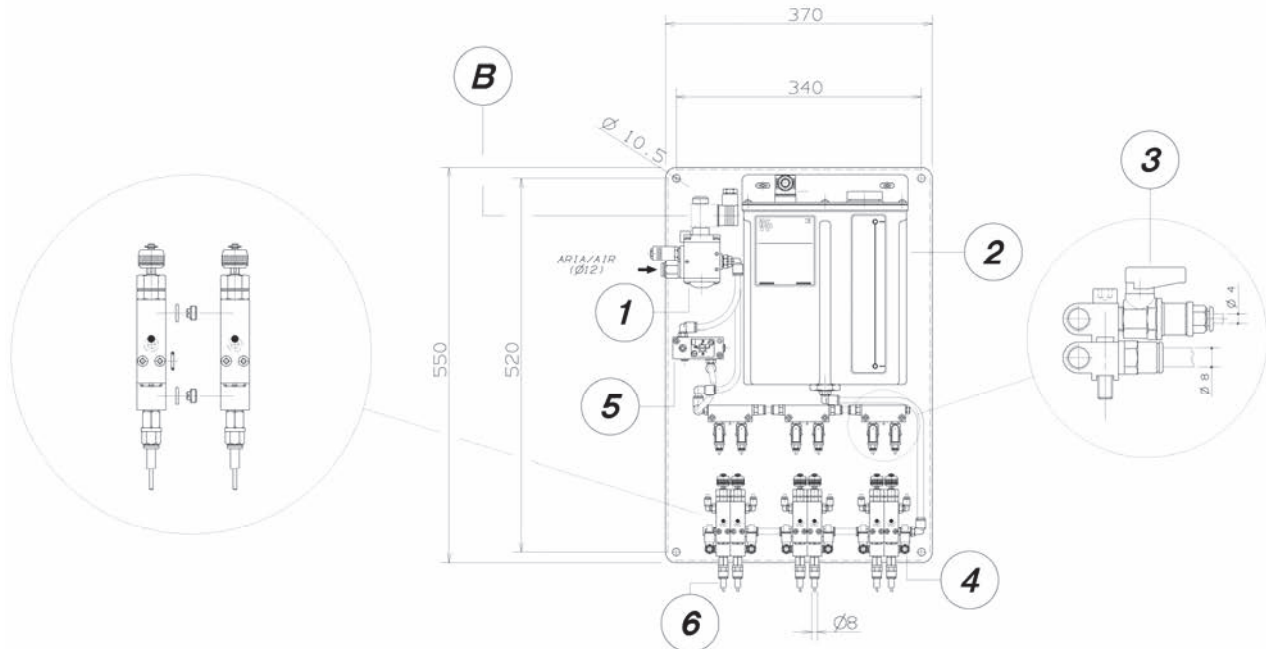

CODICE CODE	MANDATE WAYS
70.722.4	2
70.067.9	4
70.099.5	6

B	BOBINA	B	COIL
1	N. 2 ELETTROVALVOLE 24 V DC – 24 V AC – 115 V AC O 230 V AC LA PRIMA PER COMANDARE LE MICROPOMPE LA SECONDA PER INVIARE L'ARIA AGLI UGELLI	1	N. 2 SOLENOID VALVE 24 V DC – 24 V AC – 115 V AC OR 230 V AC FIRST TO DRIVE THE PUMPS/STROKES SECOND TO SEND AIR TO THE NOZZLE
2	SERBATOIO 6 L COMPLETO DI LIVELLO ELETTRICO 1 A 250 V AC 200 V DC 50 W	2	6 L RESERVOIR COMPLETE OF LOW LEVEL SWITCH 1 A 250 V AC 200 V DC 50 W
3	VALVOLA CHIUSURA/APERTURA ARIA POMPA	3	AIR PUMP ON/OFF VALVE
4	REGOLATORE ARIA PER UGELLO	4	NOZZLE AIR REGULATOR
5	GENERATORE DI FREQUENZA	5	FREQUENCY GENERATOR
6	5 M TUBO COASSIALE 8 MM	6	5 M COAXIAL TUBE 8 MM
I PUNTI SONO COMPLETAMENTE INDIPENDENTI E POSSONO ESSERE ESCLUSI CHIUDENDO LA VALVOLA 3 E IL CORRISPONDENTE REGOLATORE ARIA PER UGELLO. SONO DISPONIBILI SISTEMI PER LUBRIFICARE NASTRI CON LARGHEZZA INFERIORE E SUPERIORE		THE POINTS ARE INDEPENDENT AND CAN BE EXCLUDED CLOSING THE VALVE 3 AND THE CORRESPONDENT NOZZLE AIR REGULATOR. ON REQUEST IT IS POSSIBLE TO SUPPLY UNITS TO LUBRICATE STRIP WITH LOWER OR UPPER WIDTH.	

CODICI PER ORDINARE BOBINE DELL'ELETTROVALVOLA 14.662.5 – CODES TO ORDER SOLENOID VALVE 14.662.5 COILS

14.662.1.R	14.662.2.R	14.662.3.R	14.662.4.R
24 V DC	115 V AC	230 V AC	24 V AC





LUBRIFICAZIONE SOPRA E SOTTO DI UN NASTRO CON LARGHEZZA DA 50 MM A 800 MM

STRIP TOP AND BOTTOM LUBRICATION WITH WIDTH FROM 50 MM TO 800 MM

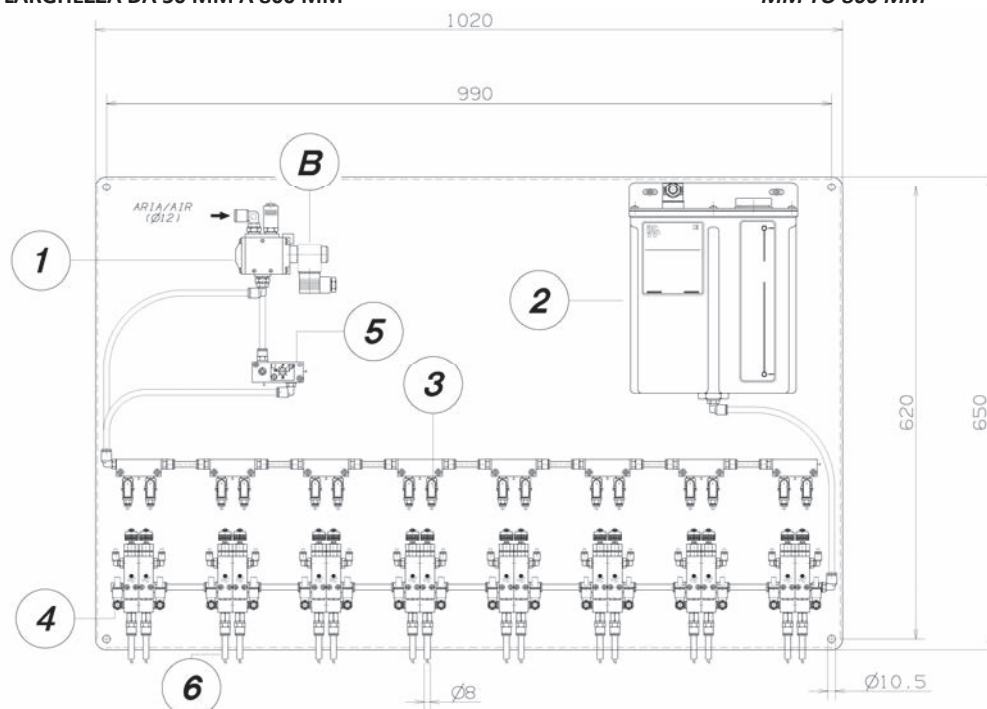

CODICE CODE	MANDATE WAYS
70.712.1	8
70.071.4	10
70.722.1	12
70.723.8	14
70.073.4	16

B	BOBINA	B	COIL
1	N. 2 ELETTROVALVOLE 24 V DC – 24 V AC – 115 V AC O 230 V AC LA PRIMA PER COMANDARE LE MICROPOMPE LA SECONDA PER INVIARE L'ARIA AGLI UGELLI	1	N. 2 SOLENOID VALVE 24 V DC – 24 V AC – 115 V AC OR 230 V AC FIRST TO DRIVE THE PUMPS/STROKES SECOND TO SEND AIR TO THE NOZZLE
2	SERBATOIO 6 L COMPLETO DI LIVELLO ELETTRICO 1 A 250 V AC 200 V DC 50 W	2	6 L RESERVOIR COMPLETE OF LOW LEVEL SWITCH 1 A 250 V AC 200 V DC 50 W
3	VALVOLA CHIUSURA/APERTURA ARIA POMPA	3	AIR PUMP ON/OFF VALVE
4	REGOLATORE ARIA PER UGELLO	4	NOZZLE AIR REGULATOR
5	GENERATORE DI FREQUENZA	5	FREQUENCY GENERATOR
6	5 M TUBO COASSIALE 8 MM	6	5 M COAXIAL TUBE 8 MM
I PUNTI SONO COMPLETAMENTE INDIPENDENTI E POSSONO ESSERE ESCLUSI CHIUDENDO LA VALVOLA 3 E IL CORRISPONDENTE REGOLATORE ARIA PER UGELLO. SONO DISPONIBILI SISTEMI PER LUBRIFICARE NASTRI CON LARGHEZZA INFERIORE E SUPERIORE		THE POINTS ARE INDEPENDENT AND CAN BE EXCLUDED CLOSING THE VALVE 3 AND THE CORRESPONDENT NOZZLE AIR REGULATOR. ON REQUEST IT IS POSSIBLE TO SUPPLY UNITS TO LUBRICATE STRIP WITH LOWER OR UPPER WIDTH.	

CODICI PER ORDINARE BOBINE DELL'ELETTROVALVOLA 14.662.5 – CODES TO ORDER SOLENOID VALVE 14.662.5 COILS

14.662.1.R	14.662.2.R	14.662.3.R	14.662.4.R
24 V DC	115 V AC	230 V AC	24 V AC



### UGELLI DI PROIEZIONE CON GETTO PIATTO PER AVANZAMENTO LENTO

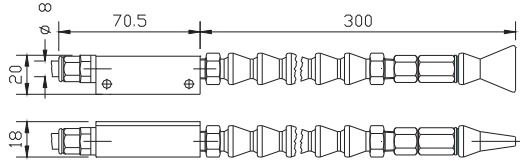

70.102.0

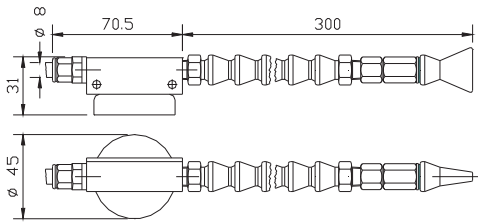

70.102.1

### FLAT NOZZLE FOR SLOW FEED

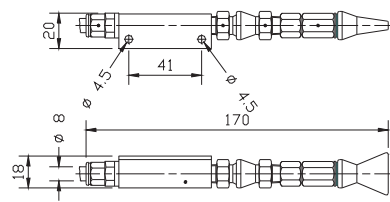

70.102.4

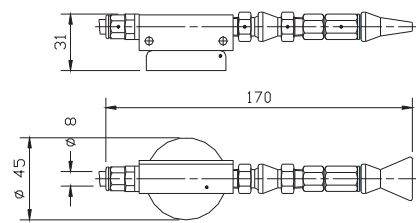

70.102.5

CODICE - CODE	DESCRIZIONE	DESCRIPTION
70.102.0	LOC-LINE CON BASE FISSA	LOC-LINE WITH FIXED BASE
70.102.1	LOC LINE CON BASE MAGNETICA	LOC-LINE WITH MAGNETIC BASE
70.102.4	BASE FISSA	FIXED BASE
70.102.5	BASE MAGNETICA	MAGNETIC BASE



### UGELLI DI PROIEZIONE CON GETTO CONICO PER AVANZAMENTO VELOCE

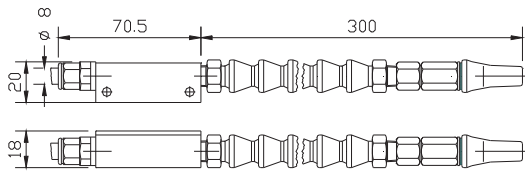

70.102.2

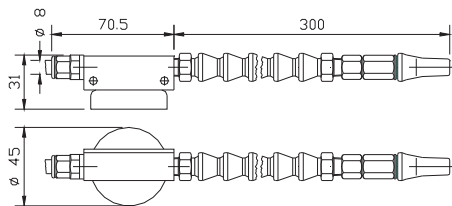

70.102.3

### CONE NOZZLE FOR HIGH FEED

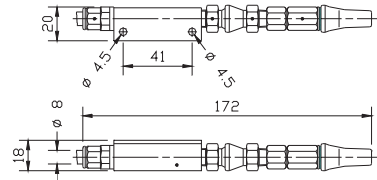

70.102.9

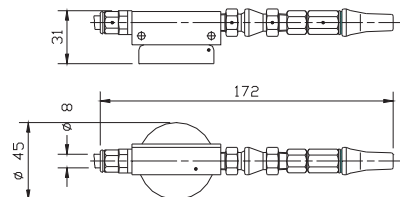

70.102.8

CODICE - CODE	DESCRIZIONE	DESCRIPTION
70.102.2	LOC-LINE CON BASE FISSA	LOC-LINE WITH FIXED BASE
70.102.3	LOC-LINE CON BASE MAGNETICA	LOC-LINE WITH MAGNETIC BASE
70.102.9	BASE FISSA	FIXED BASE
70.102.8	BASE MAGNETICA	MAGNETIC BASE



## OLIO VEGETALE NATURALE – 77

### LUBRIFICANTI INTEGRALI DI ORIGINE NATURALE

IL DIPARTIMENTO TECNICO ILC HA MESSO A PUNTO UNA SERIE DI LUBROREFRIGERANTI INTEGRALI DI ORIGINE NATURALE DENOMINATI NATURAL SERIE 77, CON IL PRECISO SCOPO DI MIGLIORARE DRASTICAMENTE LE CONDIZIONI AMBIENTALI DI LAVORO E NEL CONTEMPO FORNIRE RENDIMENTI DEGLI UTENSILI DA TAGLIO SUPERIORI A QUELLI OTTENIBILI CON L'UTILIZZO DEI TRADIZIONALI OLI DA TAGLIO MINERALI INTEGRALI. LA SERIE NATURAL 77 È COMPLETAMENTE ESENTE DA QUALSIASI OLIO MINERALE LUBRIFICANTE ED È COMPOSTA PER LA SUA TOTALITÀ DA ESTERI SINTETICI DERIVATI DA MATERIE PRIME DI ORIGINE NATURALE. INODORI, DI COLORE CHIARO, I PRODOTTI SONO COMPLETAMENTE BIODEGRADABILI ED ASSOLUTAMENTE NON NOCIVI; L'USO DELLA SERIE NATURAL 77 TOGLIE COMPLETAMENTE LA CAUSA DI RISCHIO RELATIVA ALL'USO DI OLI MINERALI E DI CONSEGUENZA LE VISITE MEDICHE PERIODICHE OBBLIGATORIE.

LA SERIE NATURAL 77 HA INOLTRE UN OTTIMO POTERE LUBRIFICANTE UNITO A PREROGATIVE DI ESTREMA PRESSIONE ED UNA BUONA AZIONE RAFFREDDANTE CHE LA RENDE IDONEA AD OTTENERE I MASSIMI RISULTATI CON FORTI AVANZAMENTI E CON IL TIPO DI UTENSILE IN USO, EVITANDO BRUCIATURE E GRIPPAGGI.

LA SERIE NATURAL 77 HA ANCHE LA PREROGATIVA DI RIDURRE I FUMI A MANIFESTAZIONI NON SIGNIFICATIVE, HA UNA BASSA VOLATILITÀ CHE RIDUCE NOTEVOLMENTE I CALI PER IL VAPORE, UNA NOTEVOLE STABILITÀ CHIMICA TALE DA EVITARE POLIMERIZZAZIONE O DEGRADAZIONE DEL PRODOTTO IN UTILIZZO; PER ULTIMO MA NON MENO IMPORTANTE, IL NATURAL 77 HA LA CARATTERISTICA DI AUTOSPEGNERSI ISTANTANEAMENTE ALL'INSORGERE DI UN INNESCO DI INCENDIO.

NATURAL 77 È UN FLUIDO INTEGRALE A COMPLESSA ADDITIVAZIONE, CON ELEVATO POTERE ANTISALDANTE E SPICCATO RESISTENZA ALLE ESTREME PRESSIONI CHE, UTILIZZATO UNITAMENTE AD UTENSILI O INSERTI IN METALLO CERAMICO, PERMETTE DI RADDOPPIARE LA VELOCITÀ DI AVANZAMENTO RISPETTO AI PARAMETRI ABITUALI DI UTILIZZO. L'USO DEL NATURAL 77 ELIMINA I FUMI IMPONENTI CHE SI FORMEREBBERO CON OLI TRADIZIONALI ALL'INCREMENTO DELLE VELOCITÀ DI AVANZAMENTO SOPRA INDICATE. IL NATURAL 77 È IDONEO INOLTRE PER ESSERE UTILIZZATO SU MACCHINE DENTATRICI CHE UTILIZZANO SIA SISTEMI DI TAGLIO TIPO "GLEASON", SIA STOZZE TIPO "FELLOWS". IL NATURAL 77 È INOLTRE COMPLETAMENTE PRIVO DI CLORO E SUOI DERIVATI.

## VEGETABLE OIL NATURAL – 77

### INTEGRAL LUBRICANT OF NATURAL ORIGINS

ILC TECHNICAL DEPARTMENT HAS SET A SERIES OF LUBRICANT/COOLANT OF NATURAL ORIGINS CALLED NATURAL 77 SERIES, WITH THE PRECISE AIM OF IMPROVING DRAMATICALLY THE WORKING ENVIRONMENT CONDITIONS AND IN THE MEANWHILE TO SUPPLY CUTTING TOOLS PERFORMANCES HIGHER TO THAT ACHIEVABLE WITH THE USE OF TRADITIONAL CUTTING NEAT MINERAL OILS. NATURAL 77 SERIES IS WHOLLY FREE FROM ANY LUBRICANT MINERAL OIL AND IT IS COMPOSED TOTALLY BY SYNTHETIC ESTERS DERIVED FROM RAW MATERIALS OF NATURAL ORIGINS. ODOURLESS, LIGHT-COLOURED, THESE PRODUCTS ARE WHOLLY BIODEGRADABLE AND ABSOLUTELY NON-TOXIC, THE USE OF NATURAL 77 SERIES AVOIDS TOTALLY THE RISK DUE TO THE USE OF MINERAL OILS AND CONSEQUENTLY THE PERIODICAL MEDICAL VISIT.

IN ADDITION, NATURAL 77 SERIES HAS AN EXCEPTIONAL LUBRICANT POWER COMBINED WITH EXTREME PRESSURE PREROGATIVES AND A GOOD COOLING ACTION WHICH KEEPS IT SUITABLE TO OBTAIN MAXIMAL RESULTS WITH STRONG FEEDS AND WITH THE TYPE OF WORKING TOOL, AVOIDING GASSINGS AND SEIZING-UP.

NATURAL 77 SERIES HAS EVEN THE PREROGATIVE TO REDUCE SMOKES, HAS LOW VOLATILITY WHICH REDUCES NOTEWORTHY STEAM REDUCTION, SUCH AN EXCELLENT CHEMICAL STABILITY TO AVOID POLYMERISATION OR DEGRADATION OF THE USING PRODUCT; LAST, BUT NOT THE LEAST, NATURAL 77 HAS THE CHARACTERISTIC OF AUTO EXTINGUISHING IMMEDIATELY AT THE ARISING OF A FIRE TRIGGER.

NATURAL 77 IS A NEAT FLUID WITH COMPLEX ADDITIVATION, WITH VERY HIGH ANTI-WELDING POWER AND CONSPICUOUS EXTREME PRESSURE RESISTANCE, AND, USED WITH TOOLS OR CERAMIC METAL INSERTS, IT ALLOWS TO DOUBLE THE FEED SPEED IN COMPARISON WITH THE USUAL PARAMETERS OF USAGE. THE USE OF NATURAL 77 AVOIDS SMOKES THAT WOULD DEVELOP WITH TRADITIONAL OILS DURING THE INCREASING FEED SPEEDS MENTIONED ABOVE. FURTHERMORE, NATURAL 77 IS SUITABLE TO BE USED ON GEAR-CUTTING MACHINES USING BOTH CUTTING SYSTEMS SUCH AS "GLEASON" AND SLOTTING MACHINE SUCH AS "FELLOWS". NATURAL 77 IS ALSO WHOLLY FREE OF CHLORINE AND ITS DERIVATIVES.

PRODOTTO PRODUCT	PESO SPECIFICO A 15 °C KG/L SPECIFIC GRAVITY AT 15 °C KG/L	VISCOSITÀ' cSt A 40 °C VISCOSITY cSt A 40 °C	PUNTO D'INFIAMMABILITÀ' °C FLASH POINT °C
NATURAL 77	0.928	68	290
CODICE / CODE	DESCRIZIONE / DESCRIPTION		Q.TA' / Q.TY
30.600.6	5 L OLIO VEGETALE NATURALE 77 / 5 L VEGETABLE OIL NATURAL 77		1



## COMPONENTI SERBATOI

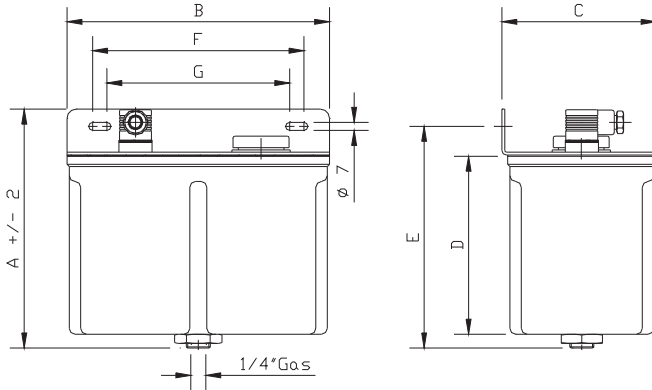

## COMPONENTS RESERVOIRS



CODICE CODE	CAPACITA' - L CAPACITY - L	LIVELLO ELETTRICO LOW LEVEL SWITCH	A MM	B MM	C MM	D MM	E MM	F MM	G MM
A72.079263	1.2 Poliestere / Polyester		161	148	123	108	146	132	125
A72.079264	2.2 Poliestere / Polyester		213	148	123	160	198	132	125
A72.079265	3.6 Poliestere / Polyester		208	230	135	155	193	185	160
A72.079269	6.0 Nylon		303	230	135	250	288	185	160
A72.079260	1.2 Poliestere / Polyester	***	161	148	123	108	146	132	125
A72.079261	2.2 Poliestere / Polyester	***	213	148	123	160	198	132	125
A72.079262	3.6 Poliestere / Polyester	***	208	230	135	155	193	185	160
A72.079268	6.0 Nylon	***	303	230	135	250	288	185	160

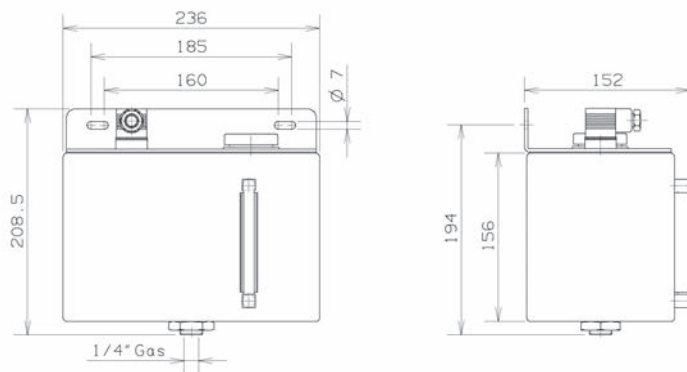

CODICE CODE	CAPACITA' - L CAPACITY - L	LIVELLO ELETTRICO LOW LEVEL SWITCH
A72.079399	3.6 Metallico / Metallic	***
A72.079399.SL	3.6 Metallico / Metallic	





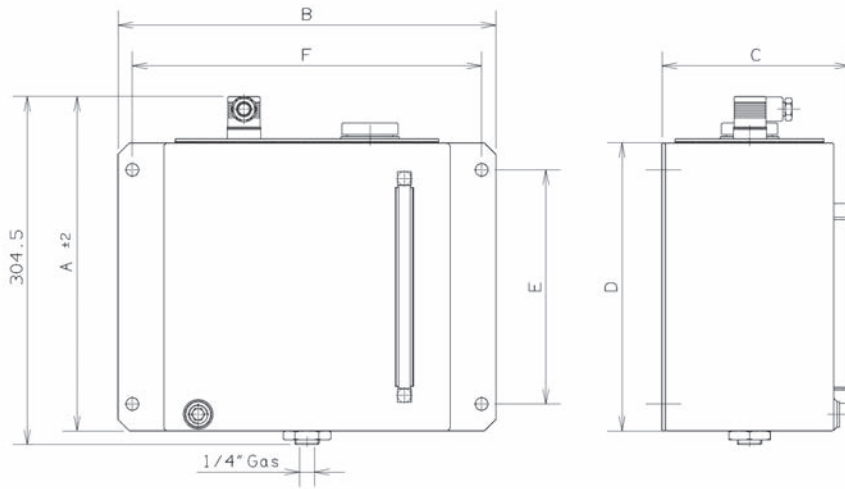

CODICE CODE	CAPACITA' - L CAPACITY - L	LIVELLO ELETTRICO LOW LEVEL SWITCH	A MM	B MM	C MM	D MM	E MM	F MM
A72.079415	8.0 Metallico / <i>Metallic</i>	***	305	330	163	252	205	305
A72.079324	12.0 Metallico / <i>Metallic</i>	***	305	355	196	252	205	330
A72.079420	50.0 Metallico / <i>Metallic</i>	***	452	560	266	400	300	530
A72.079415.SL	8.0 Metallico / <i>Metallic</i>		282	330	163	252	205	305
A72.079324.SL	12.0 Metallico / <i>Metallic</i>		282	355	196	252	205	330
A72.079420.SL	50.0 Metallico / <i>Metallic</i>		429	560	266	400	300	530





**COMPONENTI  
LIVELLI ELETTRICI**

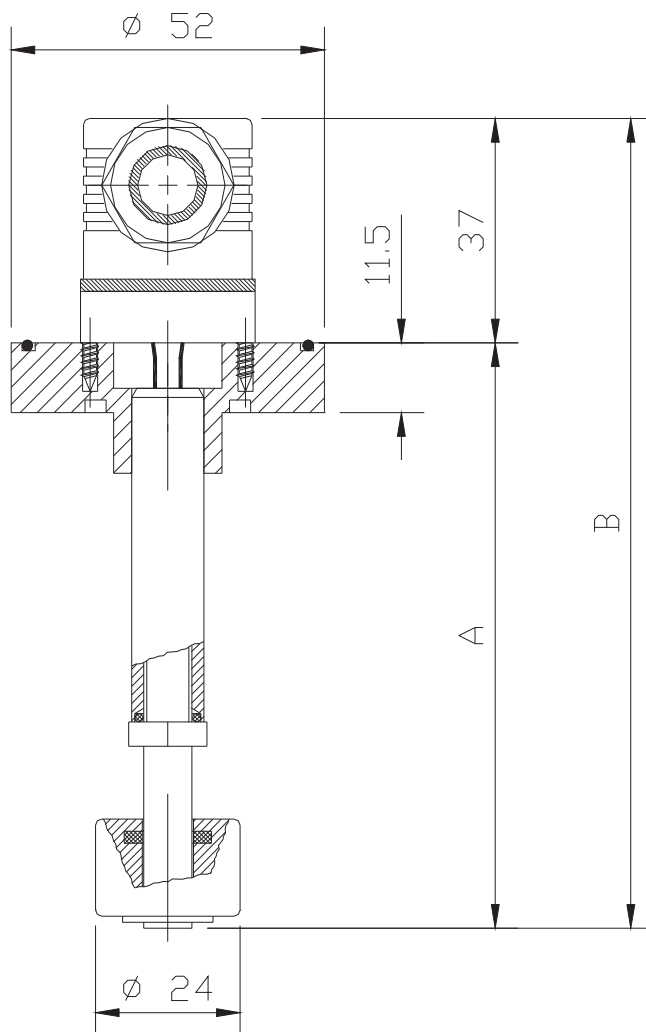

**COMPONENTS  
LOW LEVEL SWITCHES**



CODICE CODE	SERBATOIO L RESERVOIR L	A MM	B MM
A70.094040	1.20	97	133.5
A70.094029	2.20	144	181
A70.094029	3.60	144	181
A70.094037	6.00	240	277



### COMPONENTI

RACCORDI RAPIDI PER COLLEGARE L'USCITA DEL SERBATOIO AD UN TUBO DA 8 MM

RACCORDO DIRITTO  
STRAIGHT FITTING

A92.106123

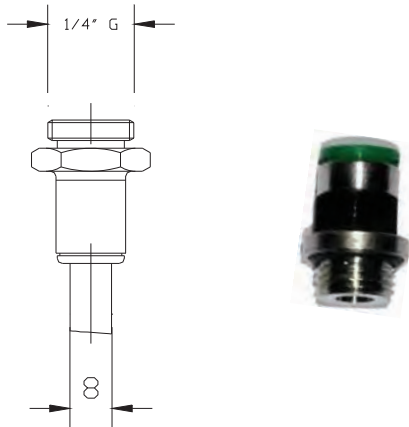

### COMPONENTS

PUSH-IN FITTINGS TO CONNECT RESERVOIR OUTLET TO AN 8 MM TUBE

RACCORDO A 90 GRADI  
ELBOW FITTING

A92.106248

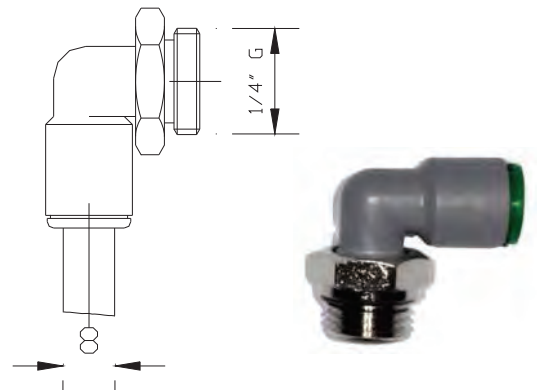

ADATTATORE PER MINI LUBETOOLS CON 1 O 2 POMPE

UNA POMPA

ONE PUMPS

A51.106208

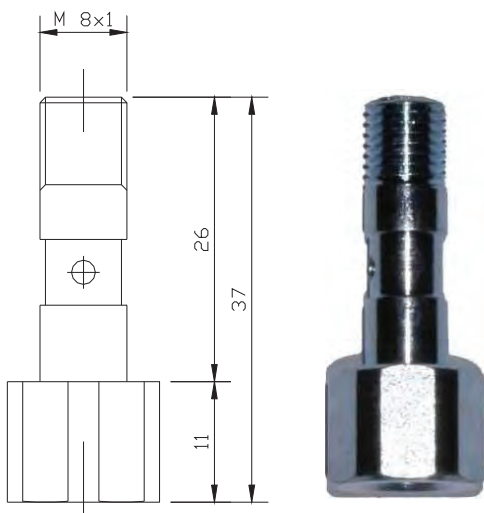

ADAPTORS FOR MINI LUBETOOLS WITH 1 OR 2 PUMPS

DUE POMPE

TWO PUMPS

A51.106215

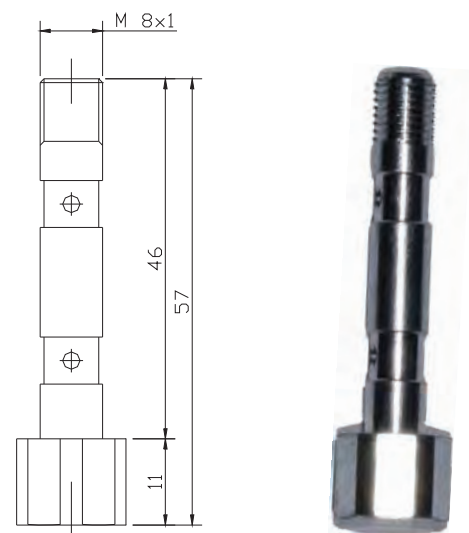

STAFFA PER INSTALLARE LE BASI DELLE POMPE (DA 1 A 6 POMPE)

BRACKET TO INSTALL THE BASE PUMPS (FROM 1 TO 6 PUMPS)

A85.120401

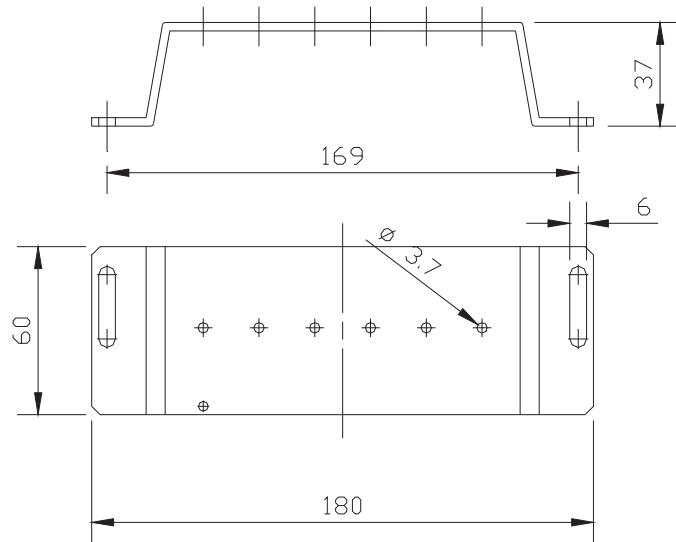

TIRANTI PER UNIRE LE BASI DELLE POMPE

TIE-RODS TO JOIN THE PUMP BASES



CODICE CODE	USCITE OUTLETS	A
A70.093167 (x2)	2	35
A70.093168 (x2)	3	55
A70.093169 (x2)	4	75
A70.093170 (x2)	5	95
A70.093171 (x2)	6	115



**BASE POMPA**  
**IL CODICE A70.093165 E' COMPLETO DI TUTTI GLI ITEM**  
**MOSTRATI NEL DISEGNO**

**PUMP BASE**  
**THE CODE A70.093165 IS COMPLETE OF ALL THE ITEMS**  
**SHOWED IN THE BELOW DRAWING**

A70.093165

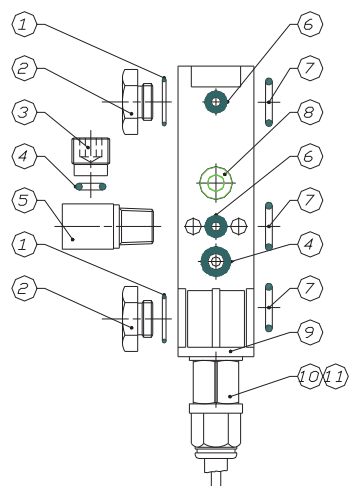

POS.	CODICE CODE	DESCRIZIONE	DESCRIPTION
1	A92.127109	"O"-RING 11x1	"O"-RING 11x1
2	A51.096055	TAPPO	PLUG
3	A73.087010	TAPPO	PLUG
4	A92.127108	"O"-RING 2018	"O"-RING 2018
5	03.231.0	ADATTATORE 90 GRADI	ELBOW ADAPTOR
6	A92.127106	"O"-RING 2010	"O"-RING 2010
7	A92.127109	"O"-RING 2037	"O"-RING 2037
8	UNI5931-M5X25	VITE M5x25 UNI 5931	SCREW M5x25 UNI 5931
9	A83.082081	BASE SINGOLA	SINGLE BASE
10	A70.093219	RACCORDO DI MANDATA + TUBO COASSIALE DA 5 M – 6 MM	DELIVERY FITTING + 5 M COAXIAL TUBE – 6 MM
11	A70.093228	RACCORDO DI MANDATA + TUBO COASSIALE DA 5 M – 8 MM	DELIVERY FITTING + 5 M COAXIAL TUBE – 8 MM

MICRO POMPA PNEUMATICA DA INSTALLARE SULLA BASE

MICRO PNEUMATIC PUMP TO BE INSTALLED ON THE BASE

A70.093463

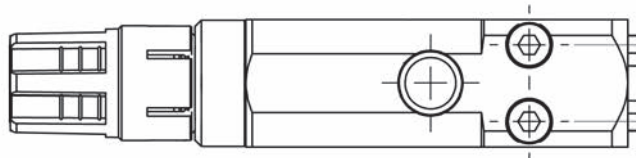
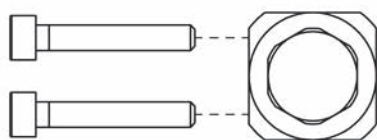

## RACCORDI PER LA BASE DELLA POMPA

## FITTINGS FOR PUMP BASE

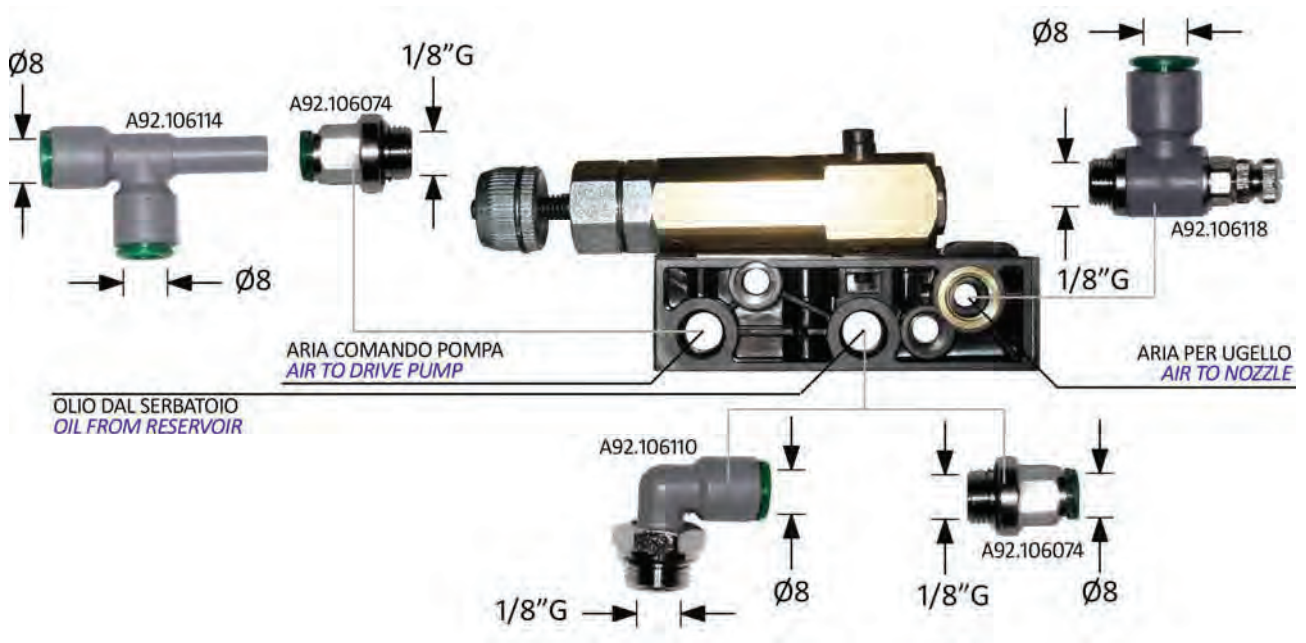

## UGELLO COMPLETO DI RACCORDO PER TUBO 6 MM

## NOZZLE COMPLETE OF FITTING FOR TUBE 6 MM

RACCORDO TUBO CON  
DOPPIOCONO

NUT AND OLIVE FITTING

RACCORDO RAPIDO

PUSH-IN FITTING

A70.093172

A70.093180

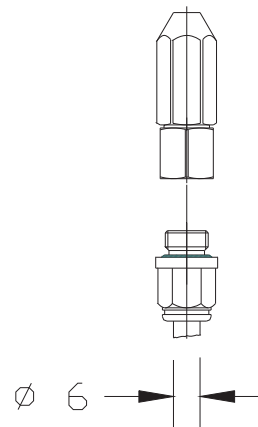
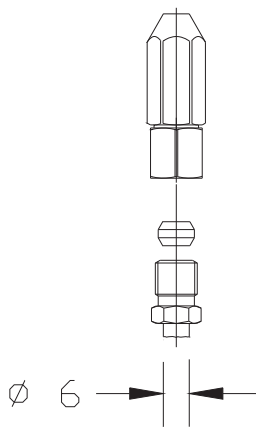

GENERATORE DI FREQUENZA COMPLETO DI BASE

FREQUENCY GENERATOR COMPLETE OF BASE

A72.079243

**	ARIA PER POMPE PNEUMATICHE	AIR FOR PNEUMATIC PUMPS
*	ARIA PER UGELLI	AIR FOR NOZZLE

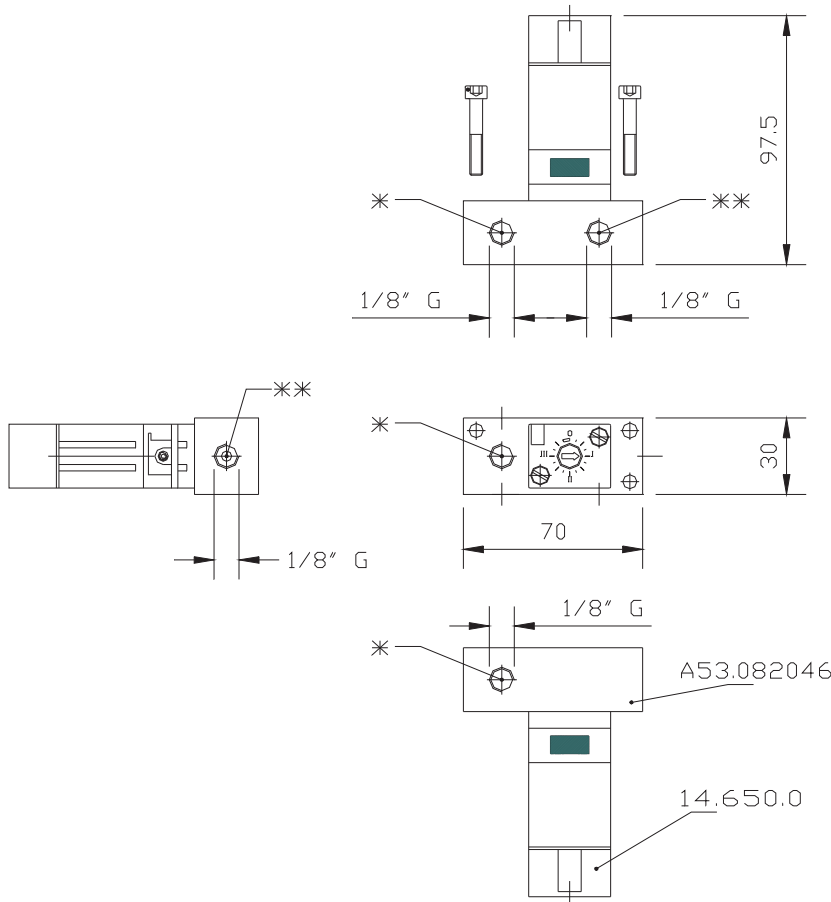

base A70.093491

RACCORDI BASE E TAPPO

BASE FITTINGS AND PLUG

A92.106110

A92.106074

A92.087058

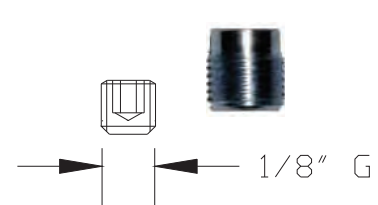
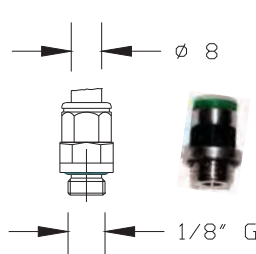
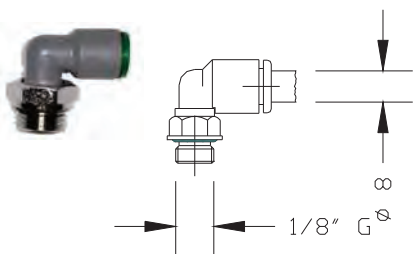



## GENERATORE DI FREQUENZA COMPLETO DI BASE

QUESTA VERSIONE VIENE UTILIZZATA PER LA SERIE MINI CON UNA O DUE POMPE

## FREQUENCY GENERATOR COMPLETE OF BASE

THIS IS USED FOR THE MINI VERSION WITH ONE OR TWO PUMPS

A72.079321

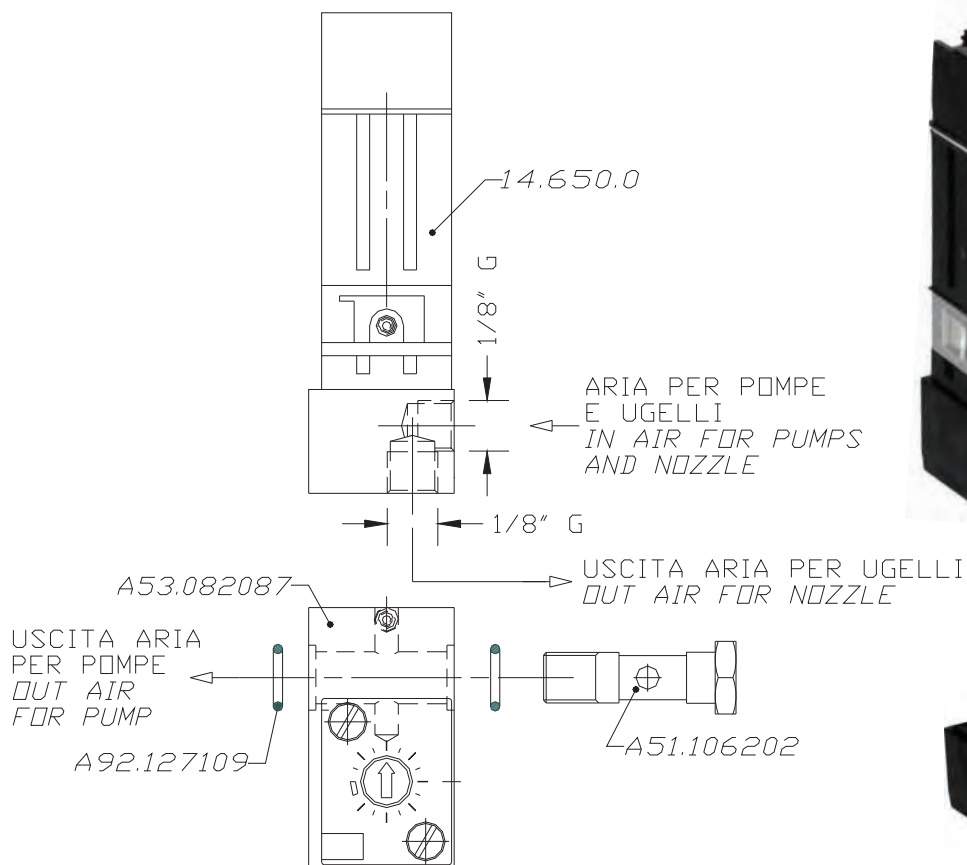

base A70.093504

### RACCORDI BASE E TAPPO

### BASE FITTINGS AND PLUG

A92.106110

A92.106074

A92.087058

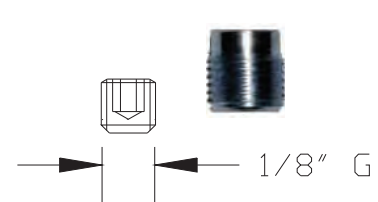
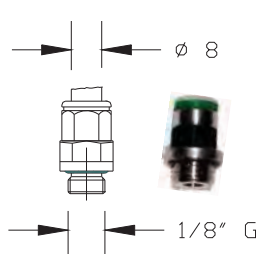
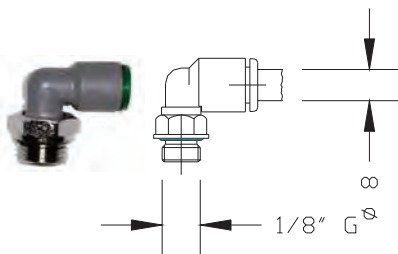

## ELETTROVALVOLE

## SOLENOID VALVES

Codice Code	Descrizione	Description	Immagine Image
<p><b>14.660.0</b></p> <p>14.660.1 14.660.2 14.660.3 14.660.4</p>	<p><b>Elettrovalvola</b>                      Connessioni: 1/4" Gas                      Diametro passaggio (mm): 6                      Portata (NI/min): 620                      Pressione max (BAR): 10</p> <p>Bobina 24 V DC                      Bobina 115 V AC                      Bobina 230 V AC                      Bobina 24 V AC</p>	<p><b>Solenoid valve</b>                      Connection: 1/4" G                      Orifice size (mm): 6                      Discharge (NI/min): 620                      Max Pressure (BAR): 10</p> <p>Coil 24 V DC                      Coil 115 V AC                      Coil 230 V AC                      Coil 24 V AC</p>	
<p><b>14.663.5</b></p> <p>14.660.1 14.660.2 14.660.3 14.660.4</p>	<p><b>Elettrovalvola</b>                      Connessioni: 1/8" Gas                      Diametro passaggio (mm): 1,5                      Portata (NI/min): 60                      Pressione max (BAR): 10</p> <p>Bobina 24 V DC                      Bobina 115 V AC                      Bobina 230 V AC                      Bobina 24 V AC</p>	<p><b>Solenoid valve</b>                      Connection: 1/8" G                      Orifice size (mm): 1,5                      Discharge (NI/min): 60                      Max Pressure (BAR): 10</p> <p>Coil 24 V DC                      Coil 115 V AC                      Coil 230 V AC                      Coil 24 V AC</p>	
<p><b>14.662.5</b></p> <p>14.662.1 14.662.2 14.662.3 14.662.4</p>	<p><b>Elettrovalvola</b>                      Connessioni: 3/8" Gas                      Diametro passaggio (mm): 10                      Portata (NI/min): 1500                      Pressione max (BAR): 10</p> <p>Bobina 24 V DC                      Bobina 115 V AC                      Bobina 230 V AC                      Bobina 24 V AC</p>	<p><b>Solenoid valve</b>                      Connection: 3/8" G                      Orifice size (mm): 10                      Discharge (NI/min): 1500                      Max Pressure (BAR): 10</p> <p>Coil 24 V DC                      Coil 115 V AC                      Coil 230 V AC                      Coil 24 V AC</p>	



TUBI COASSIALI COMPLETI DI RACCORDO, ADATTATORE E UGELLO PER LA BASE DELLA POMPA

COAXIAL HOSES COMPLETE OF FITTING, ADAPTOR AND NOZZLE FOR THE PUMP BASE

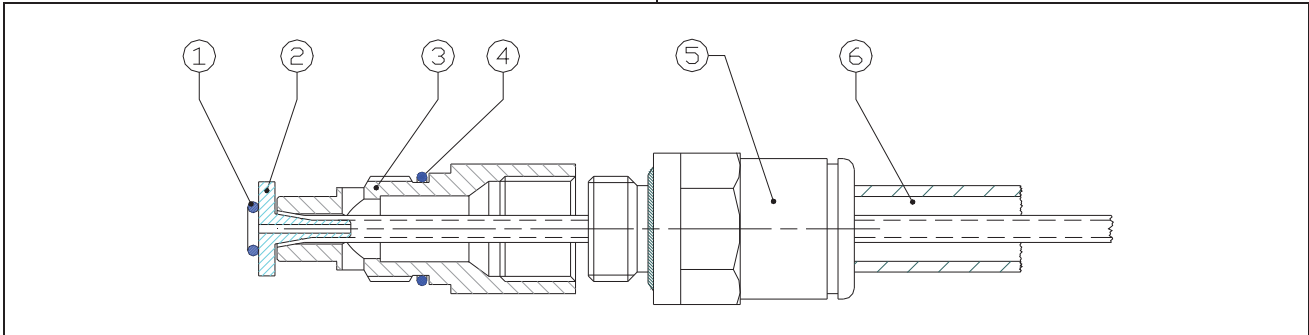

CODICI DI ORDINAZIONE

CODES TO ORDER

Mt	Ø6	Ø8	Ø10
1,5	A70.093458	---	---
3	A70.093453	---	---
4	A70.093438	---	---
5	A70.093219	A70.093228	A70.093475
6	A70.093253	A70.093257	---
7	A70.093254	A70.093258	---
8	A70.093255	A70.093259	---
9	A70.093256	A70.093260	---
10	A70.093250	A70.093249	A70.093476
15	A70.093412	A70.093418	A70.093477
20	---	A70.093469	A70.093478
25	---	---	A70.093479
30	---	A70.093470	A70.093471



POS	DESCRIZIONE	DESCRIPTION	CODICE - CODE
1	"O"-RING 3x1	O"-RING 3x1	A92.127034
2	BUSSOLA PORTA TUBO PER BASE	NOZZE FOR PUMP BASE	A52.090051
3	ADATTATORE	ADAPTOR	A51.106104
4	"O"-RING 8x1	"O"-RING 8x1	A73.127065
5	RACCORDO RAPIDO	PUSH-IN FITTING	*
6	TUBAZIONE COASSIALE	COAXIAL HOSE	**

	DESCRIZIONE	DESCRIPTION	CODICE - CODE
*	RACCORDO RAPIDO 1/8" TUBO 6 MM	PUSH-IN FITTING 1/8" HOSE 6 MM	A92.106113
*	RACCORDO RAPIDO 1/8" TUBO 8 MM	PUSH-IN FITTING 1/8" HOSE 8 MM	A92.106074
*	RACCORDO RAPIDO 1/4" TUBO 10 MM	PUSH-IN FITTING 1/4" HOSE 10 MM	03.214.0 + A92.106191

**			
Mt	Ø6	Ø8	Ø10
1	70.150.1	70.160.1	70.170.1
2	70.150.2	70.160.2	70.170.2
3	70.150.3	70.160.3	70.170.3
4	70.150.4	70.160.4	70.170.4
5	70.150.5	70.160.5	70.170.5
6	70.150.6	70.160.6	70.170.6
7	70.150.7	70.160.7	70.170.7
8	70.150.8	70.160.8	70.170.8
9	70.150.9	70.160.9	70.170.9
10	70.151.0	70.161.0	70.171.0
11	70.151.1	70.161.1	70.171.1
12	70.151.2	70.161.2	70.171.2
13	70.151.3	70.161.3	70.171.3
14	70.151.4	70.161.4	70.171.4
15	70.151.5	70.161.5	70.171.5
16	70.151.6	70.161.6	70.171.6
17	70.151.7	70.161.7	70.171.7
18	70.151.8	70.161.8	70.171.8
19	70.151.9	70.161.9	70.171.9
20	70.152.0	70.162.0	70.172.0
21	70.152.1	70.162.1	70.172.1
22	70.152.2	70.162.2	70.172.2
23	70.152.3	70.162.3	70.172.3
24	70.152.4	70.162.4	70.172.4
25	70.152.5	70.162.5	70.172.5
30	70.153.0	70.163.0	70.173.0



**TUBI COASSIALI METALLICI COMPLETI DI RACCORDO, ADATTATORE E UGELLO PER LA BASE DELLA POMPA**

**METALLIC COAXIAL HOSES COMPLETE OF FITTING, ADAPTOR AND NOZZLE FOR THE PUMP BASE**

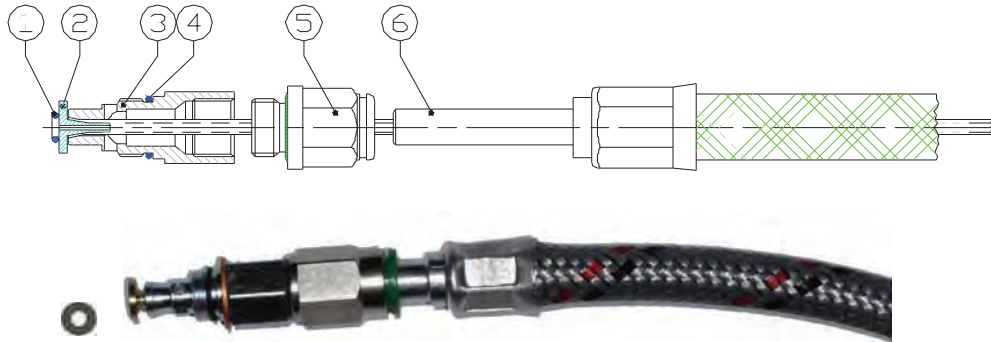

CODICI DI ORDINAZIONE

CODES TO ORDER

CODICE - CODE	DESCRIZIONE	DESCRIPTION
A70.093351	1 M TUBO COASSIALE CODULO 8 MM COMPLETO DI RACCORDO, ADATTATORE E UGELLO PER LA BASE DELLA POMPA	1 M COAXIAL HOSE TERMINAL 8 MM COMPLETE OF FITTING, ADAPTOR AND NOZZLE FOR THE PUMP BASE
A70.093352	2 M TUBO COASSIALE CODULO 8 MM COMPLETO DI RACCORDO, ADATTATORE E UGELLO PER LA BASE DELLA POMPA	2 M COAXIAL HOSE TERMINAL 8 MM COMPLETE OF FITTING, ADAPTOR AND NOZZLE FOR THE PUMP BASE
A70.093353	3 M TUBO COASSIALE CODULO 8 MM COMPLETO DI RACCORDO, ADATTATORE E UGELLO PER LA BASE DELLA POMPA	3 M COAXIAL HOSE TERMINAL 8 MM COMPLETE OF FITTING, ADAPTOR AND NOZZLE FOR THE PUMP BASE
A70.093354	4 M TUBO COASSIALE CODULO 8 MM COMPLETO DI RACCORDO, ADATTATORE E UGELLO PER LA BASE DELLA POMPA	4 M COAXIAL HOSE TERMINAL 8 MM COMPLETE OF FITTING, ADAPTOR AND NOZZLE FOR THE PUMP BASE
A70.093355	5 M TUBO COASSIALE CODULO 8 MM COMPLETO DI RACCORDO, ADATTATORE E UGELLO PER LA BASE DELLA POMPA	5 M COAXIAL HOSE TERMINAL 8 MM COMPLETE OF FITTING, ADAPTOR AND NOZZLE FOR THE PUMP BASE
A70.093356	6 M TUBO COASSIALE CODULO 8 MM COMPLETO DI RACCORDO, ADATTATORE E UGELLO PER LA BASE DELLA POMPA	6 M COAXIAL HOSE TERMINAL 8 MM COMPLETE OF FITTING, ADAPTOR AND NOZZLE FOR THE PUMP BASE
A70.093357	7 M TUBO COASSIALE CODULO 8 MM COMPLETO DI RACCORDO, ADATTATORE E UGELLO PER LA BASE DELLA POMPA	7 M COAXIAL HOSE TERMINAL 8 MM COMPLETE OF FITTING, ADAPTOR AND NOZZLE FOR THE PUMP BASE
A70.093358	8 M TUBO COASSIALE CODULO 8 MM COMPLETO DI RACCORDO, ADATTATORE E UGELLO PER LA BASE DELLA POMPA	8 M COAXIAL HOSE TERMINAL 8 MM COMPLETE OF FITTING, ADAPTOR AND NOZZLE FOR THE PUMP BASE
A70.093359	9 M TUBO COASSIALE CODULO 8 MM COMPLETO DI RACCORDO, ADATTATORE E UGELLO PER LA BASE DELLA POMPA	9 M COAXIAL HOSE TERMINAL 8 MM COMPLETE OF FITTING, ADAPTOR AND NOZZLE FOR THE PUMP BASE
A70.093360	10 M TUBO COASSIALE CODULO 8 MM COMPLETO DI RACCORDO, ADATTATORE E UGELLO PER LA BASE DELLA POMPA	10 M COAXIAL HOSE TERMINAL 8 MM COMPLETE OF FITTING, ADAPTOR AND NOZZLE FOR THE PUMP BASE



A70.093341	1 M TUBO COASSIALE CODULO 6 MM COMPLETO DI RACCORDO, ADATTATORE E UGELLO PER LA BASE DELLA POMPA	1 M COAXIAL HOSE TERMINAL 6 MM COMPLETE OF FITTING, ADAPTOR AND NOZZLE FOR THE PUMP BASE
A70.093342	2 M TUBO COASSIALE CODULO 6 MM COMPLETO DI RACCORDO, ADATTATORE E UGELLO PER LA BASE DELLA POMPA	2 M COAXIAL HOSE TERMINAL 6 MM COMPLETE OF FITTING, ADAPTOR AND NOZZLE FOR THE PUMP BASE
A70.093343	3 M TUBO COASSIALE CODULO 6 MM COMPLETO DI RACCORDO, ADATTATORE E UGELLO PER LA BASE DELLA POMPA	3 M COAXIAL HOSE TERMINAL 6 MM COMPLETE OF FITTING, ADAPTOR AND NOZZLE FOR THE PUMP BASE
A70.093344	4 M TUBO COASSIALE CODULO 6 MM COMPLETO DI RACCORDO, ADATTATORE E UGELLO PER LA BASE DELLA POMPA	4 M COAXIAL HOSE TERMINAL 6 MM COMPLETE OF FITTING, ADAPTOR AND NOZZLE FOR THE PUMP BASE
A70.093345	5 M TUBO COASSIALE CODULO 6 MM COMPLETO DI RACCORDO, ADATTATORE E UGELLO PER LA BASE DELLA POMPA	5 M COAXIAL HOSE TERMINAL 6 MM COMPLETE OF FITTING, ADAPTOR AND NOZZLE FOR THE PUMP BASE
A70.093346	6 M TUBO COASSIALE CODULO 6 MM COMPLETO DI RACCORDO, ADATTATORE E UGELLO PER LA BASE DELLA POMPA	6 M COAXIAL HOSE TERMINAL 6 MM COMPLETE OF FITTING, ADAPTOR AND NOZZLE FOR THE PUMP BASE
A70.093347	7 M TUBO COASSIALE CODULO 6 MM COMPLETO DI RACCORDO, ADATTATORE E UGELLO PER LA BASE DELLA POMPA	7 M COAXIAL HOSE TERMINAL 6 MM COMPLETE OF FITTING, ADAPTOR AND NOZZLE FOR THE PUMP BASE
A70.093348	8 M TUBO COASSIALE CODULO 6 MM COMPLETO DI RACCORDO, ADATTATORE E UGELLO PER LA BASE DELLA POMPA	8 M COAXIAL HOSE TERMINAL 6 MM COMPLETE OF FITTING, ADAPTOR AND NOZZLE FOR THE PUMP BASE
A70.093349	9 M TUBO COASSIALE CODULO 6 MM COMPLETO DI RACCORDO, ADATTATORE E UGELLO PER LA BASE DELLA POMPA	9 M COAXIAL HOSE TERMINAL 6 MM COMPLETE OF FITTING, ADAPTOR AND NOZZLE FOR THE PUMP BASE
A70.093350	10 M TUBO COASSIALE CODULO 6 MM COMPLETO DI RACCORDO, ADATTATORE E UGELLO PER LA BASE DELLA POMPA	10 M COAXIAL HOSE TERMINAL 6 MM COMPLETE OF FITTING, ADAPTOR AND NOZZLE FOR THE PUMP BASE

POS	DESCRIZIONE	DESCRIPTION	CODICE - CODE
1	"O"-RING 3x1	O"-RING 3x1	A92.127034
2	BUSSOLA PORTA TUBO PER BASE	NOZZE FOR PUMP BASE	A52.090051
3	ADATTATORE	ADAPTOR	A51.106104
4	"O"-RING 8x1	"O"-RING 8x1	A73.127065
5	RACCORDO RAPIDO	PUSH-IN FITTING	*
6	TUBAZIONE COASSIALE	COAXIAL HOSE	*

	DESCRIZIONE	DESCRIPTION	CODICE - CODE
*	RACCORDO RAPIDO 1/8" TUBO 8 MM	PUSH-IN FITTING 1/8" HOSE 8 MM	A92.106074
*	RACCORDO RAPIDO 1/8" TUBO 6 MM	PUSH-IN FITTING 1/8" HOSE 6 MM	A92.106113





## TUBI FLESSIBILI METALLICI

## METALLIC FLEXIBLE HOSES

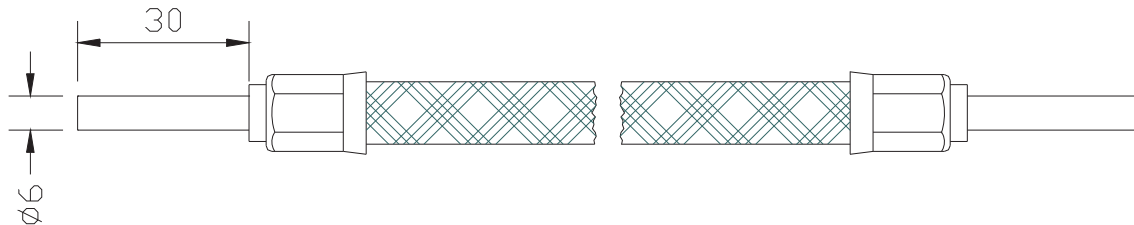

**	CODICI PER ORDINARE TUBAZIONI METALLICHE FLESSIBILI	CODES TO ORDER METALLIC FLEXIBLE HOSES
30.616.0.01000	1 M TUBO METALLICO 6 MM	1 M METALLIC HOSE 6 MM
30.616.0.02000	2 M TUBO METALLICO 6 MM	2 M METALLIC HOSE 6 MM
30.616.0.03000	3 M TUBO METALLICO 6 MM	3 M METALLIC HOSE 6 MM
30.616.0.04000	4 M TUBO METALLICO 6 MM	4 M METALLIC HOSE 6 MM
30.616.0.05000	5 M TUBO METALLICO 6 MM	5 M METALLIC HOSE 6 MM
30.616.0.06000	6 M TUBO METALLICO 6 MM	6 M METALLIC HOSE 6 MM
30.616.0.07000	7 M TUBO METALLICO 6 MM	7 M METALLIC HOSE 6 MM
30.616.0.08000	8 M TUBO METALLICO 6 MM	8 M METALLIC HOSE 6 MM
30.616.0.09000	9 M TUBO METALLICO 6 MM	9 M METALLIC HOSE 6 MM
30.616.0.10000	10 M TUBO METALLICO 6 MM	10 M METALLIC HOSE 6 MM

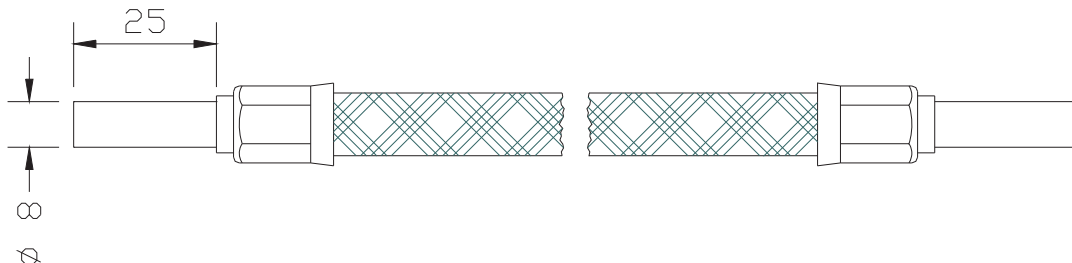

**	CODICI PER ORDINARE TUBAZIONI METALLICHE FLESSIBILI	CODES TO ORDER METALLIC FLEXIBLE HOSES
30.618.0.01000	1 M TUBO METALLICO 8 MM	1 M METALLIC HOSE 8 MM
30.618.0.02000	2 M TUBO METALLICO 8 MM	2 M METALLIC HOSE 8 MM
30.618.0.03000	3 M TUBO METALLICO 8 MM	3 M METALLIC HOSE 8 MM
30.618.0.04000	4 M TUBO METALLICO 8 MM	4 M METALLIC HOSE 8 MM
30.618.0.05000	5 M TUBO METALLICO 8 MM	5 M METALLIC HOSE 8 MM
30.618.0.06000	6 M TUBO METALLICO 8 MM	6 M METALLIC HOSE 8 MM
30.618.0.07000	7 M TUBO METALLICO 8 MM	7 M METALLIC HOSE 8 MM
30.618.0.08000	8 M TUBO METALLICO 8 MM	8 M METALLIC HOSE 8 MM
30.618.0.09000	9 M TUBO METALLICO 8 MM	9 M METALLIC HOSE 8 MM
30.618.0.10000	10 M TUBO METALLICO 8 MM	10 M METALLIC HOSE 8 MM



MAGNETI

MAGNETS

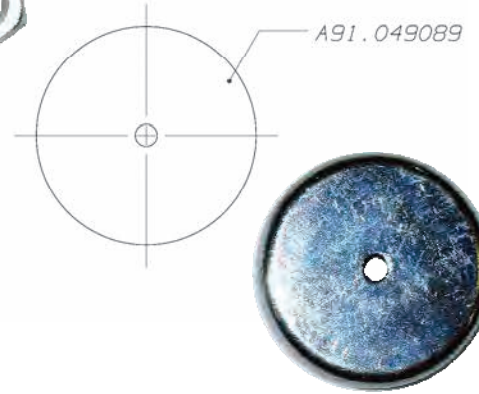
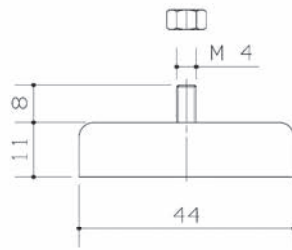
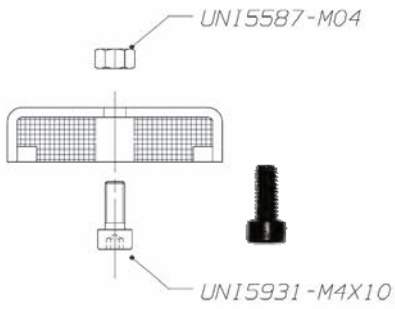



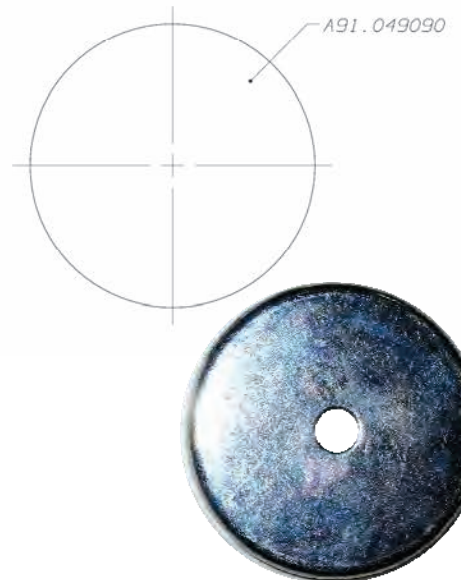
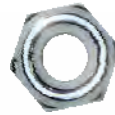
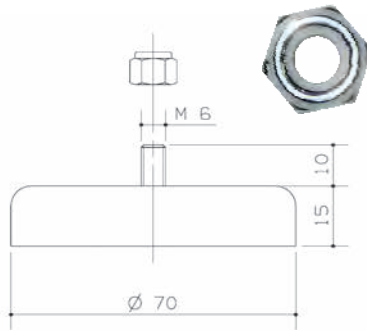
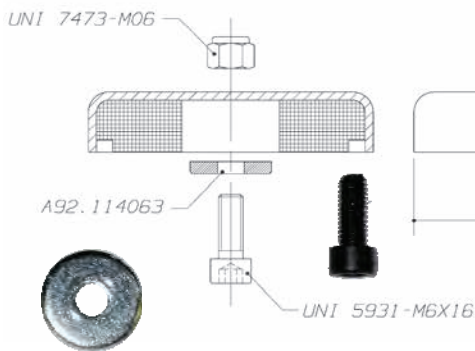

A70.093498



A70.093499



		RACCORDI		FITTINGS					
		TUBO HOSE	4 MM	TUBO HOSE	6 MM	TUBO HOSE	8 MM	TUBO HOSE	10 MM
	1/8" G	A92.106165		A92.106113		A92.106074			
	1/8" G	A92.106218		A92.106195		A92.106110			
	1 / 4" G			A92.106133		A92.106123		A92.106191	
	1 / 4" G			A92.106224		A92.106248		A92.106199	

